

[4910-13-U]

DEPARTMENT OF TRANSPORTATION

Federal Aviation Administration

14 CFR Part 39 [65 FR 25829 5/4/2000]

[Docket No. 2000-NM-93-AD; Amendment 39-11711; AD 2000-09-03]

RIN 2120-AA64

Airworthiness Directives; Boeing Model 747-400 Series Airplanes Equipped with General Electric CF6-80C2 Series Engines

AGENCY: Federal Aviation Administration, DOT.

ACTION: Final rule; request for comments.

SUMMARY: This amendment supersedes an existing airworthiness directive (AD), applicable to certain Boeing Model 747-400 series airplanes, that currently requires various inspections and functional tests to detect discrepancies of the thrust reverser control and indication system, and correction of any discrepancy found. This amendment adds an appendix and revises certain actions in the existing AD. This amendment is prompted by a report indicating that completion of the cone brake test of the center drive unit is ineffective for certain airplanes. The actions specified in this AD are intended to ensure the integrity of the fail safe features of the thrust reverser system by preventing possible failure modes in the thrust reverser control system that can result in inadvertent deployment of a thrust reverser during flight.

DATES: Effective May 19, 2000.

The incorporation by reference of certain publications, as listed in the regulations, was previously approved by the Director of the Federal Register as of March 13, 2000 (65 FR 5742, February 7, 2000).

Comments for inclusion in the Rules Docket must be received on or before July 3, 2000.

ADDRESSES: Submit comments in triplicate to the Federal Aviation Administration (FAA), Transport Airplane Directorate, ANM-114, Attention: Rules Docket No. 2000-NM-93-AD, 1601 Lind Avenue, SW., Renton, Washington 98055-4056.

The service information referenced in this AD may be obtained from Boeing Commercial Airplane Group, P.O. Box 3707, Seattle, Washington 98124-2207. This information may be examined at the FAA, Transport Airplane Directorate, 1601 Lind Avenue, SW., Renton, Washington; or at the Office of the Federal Register, 800 North Capitol Street, NW., suite 700, Washington, DC.

FOR FURTHER INFORMATION CONTACT: Holly Thorson, Aerospace Engineer, Propulsion Branch, ANM-140S, FAA, Transport Airplane Directorate, Seattle Aircraft Certification Office, 1601 Lind Avenue, SW., Renton, Washington 98055-4056; telephone (425) 227-1357; fax (425) 227-1181.

SUPPLEMENTARY INFORMATION: On January 28, 2000, the FAA issued AD 2000-02-33, amendment 39-11551 (65 FR 5742, February 7, 2000), applicable to certain Boeing Model 747-400 series airplanes, to require various inspections and functional tests to detect discrepancies of the thrust reverser control and indication system, and correction of any discrepancy found. That action was prompted by reports indicating that several center drive units (CDU) were returned to the manufacturer of the CDU's because of low holding torque of the CDU cone brake. The actions required by that AD are intended to ensure the integrity of the fail safe features of the thrust reverser system by preventing possible failure modes in the thrust reverser control system that can result in inadvertent deployment of a thrust reverser during flight.

### Actions Since Issuance of Previous Rule

Since the issuance of AD 2000-02-33, the FAA has received information indicating the following:

- Completion of the functional test of the CDU cone brake as referenced in the existing AD is ineffective for Model 747-400 series airplanes having a third locking system installed on the thrust reversers. The test for those airplanes requires an additional step to unlock the electro-mechanical brake prior to accomplishment of the functional test of the cone brake of the center drive unit. This step was omitted from the functional test described in the service bulletins and referenced in paragraph (a) of the existing AD. Therefore, Appendix 1 (including Figure 1) has been added to this AD to provide accurate instructions for airplanes that have a third locking system installed. Paragraph (a) of this AD has been revised to reference Appendix 1 (including Figure 1) as the appropriate source of service information for those airplanes.
- The grace period of 650 flight hours to accomplish the functional test of the cone brake of the CDU is expected to expire for most airplanes by May or June 2000. For airplanes that have been modified to incorporate the third locking system, this would allow accomplishment of an invalid test with potentially misleading results. The valid functional test as described in Appendix 1 (including Figure 1) of this AD imposes no additional burden.
- The previously approved alternative methods of compliance (AMOC) as referenced in paragraph (d)(2) of the existing AD should not have been included in the final rule. The notice of proposed rulemaking was issued as a supersedure, but the final rule was issued as a separate rulemaking action that addressed only those airplanes equipped with General Electric CF6-80C2 series engines; therefore, the AMOC's previously approved in accordance with AD 94-15-05, amendment 39-8976 (59 FR 37655, July 25, 1994), and specified in paragraph (d)(2) of the existing AD, are not applicable. Paragraph (d)(2) of the existing AD has been revised accordingly.
- Paragraph (a) of the existing AD states, "Within 1,000 hours time-in-service after the most recent test of the CDU cone brake performed in accordance with paragraph (b)(1) of AD 94-15-05; or within 650 hours time-in-service after the effective date of this AD, **whichever occurs first...**" The manufacturer has submitted documentation showing similar requirements are contained in paragraph (a) of AD 2000-02-20, amendment 39-11551, which is applicable to Model 767 series airplanes, and which gives the operator a longer compliance time. In that AD, the grace period for the compliance time reads, "...or within 650 hours time-in-service after the effective date of this AD, **whichever occurs later...**" Therefore, in light of the information received, the FAA has revised paragraph (a) of this AD accordingly.

### Explanation of Requirements of Rule

Since an unsafe condition has been identified that is likely to exist or develop on other airplanes of this same type design, this AD supersedes AD 2000-02-33 to continue to require various inspections and functional tests to detect discrepancies of the thrust reverser control and indication system, and correction of any discrepancy found. This AD also adds an appendix and revises certain actions in the existing AD.

### **Determination of Rule's Effective Date**

Since a situation exists that requires the immediate adoption of this regulation, it is found that notice and opportunity for prior public comment hereon are impracticable, and that good cause exists for making this amendment effective in less than 30 days.

### **Comments Invited**

Although this action is in the form of a final rule that involves requirements affecting flight safety and, thus, was not preceded by notice and an opportunity for public comment, comments are invited on this rule. Interested persons are invited to comment on this rule by submitting such written data, views, or arguments as they may desire. Communications shall identify the Rules Docket number and be submitted in triplicate to the address specified under the caption "ADDRESSES." All communications received on or before the closing date for comments will be considered, and this rule may be amended in light of the comments received. Factual information that supports the commenter's ideas and suggestions is extremely helpful in evaluating the effectiveness of the AD action and determining whether additional rulemaking action would be needed.

Comments are specifically invited on the overall regulatory, economic, environmental, and energy aspects of the rule that might suggest a need to modify the rule. All comments submitted will be available, both before and after the closing date for comments, in the Rules Docket for examination by interested persons. A report that summarizes each FAA-public contact concerned with the substance of this AD will be filed in the Rules Docket.

Commenters wishing the FAA to acknowledge receipt of their comments submitted in response to this rule must submit a self-addressed, stamped postcard on which the following statement is made: "Comments to Docket Number 2000-NM-93-AD." The postcard will be date stamped and returned to the commenter.

### **Regulatory Impact**

The regulations adopted herein will not have a substantial direct effect on the States, on the relationship between the national Government and the States, or on the distribution of power and responsibilities among the various levels of government. Therefore, it is determined that this final rule does not have federalism implications under Executive Order 13132.

The FAA has determined that this regulation is an emergency regulation that must be issued immediately to correct an unsafe condition in aircraft, and that it is not a "significant regulatory action" under Executive Order 12866. It has been determined further that this action involves an emergency regulation under DOT Regulatory Policies and Procedures (44 FR 11034, February 26, 1979). If it is determined that this emergency regulation otherwise would be significant under DOT Regulatory Policies and Procedures, a final regulatory evaluation will be prepared and placed in the Rules Docket. A copy of it, if filed, may be obtained from the Rules Docket at the location provided under the caption "ADDRESSES."

## List of Subjects in 14 CFR Part 39

Air transportation, Aircraft, Aviation safety, Incorporation by reference, Safety.

### Adoption of the Amendment

Accordingly, pursuant to the authority delegated to me by the Administrator, the Federal Aviation Administration amends part 39 of the Federal Aviation Regulations (14 CFR part 39) as follows:

#### PART 39 - AIRWORTHINESS DIRECTIVES

1. The authority citation for part 39 continues to read as follows:

Authority: 49 U.S.C. 106(g), 40113, 44701.

§ 39.13 [Amended]

2. Section 39.13 is amended by removing amendment 39-11551 (65 FR 5742, February 7, 2000), and by adding a new airworthiness directive (AD), amendment 39-11711, to read as follows:

SUPERSEDED

# AIRWORTHINESS DIRECTIVE

REGULATORY SUPPORT DIVISION  
P.O. BOX 26460  
OKLAHOMA CITY, OKLAHOMA 73125-0460



U.S. Department  
of Transportation  
**Federal Aviation  
Administration**

*AD's are posted on the internet at <http://av-info.faa.gov>*

The following Airworthiness Directive issued by the Federal Aviation Administration in accordance with the provisions of Title 14 of the Code of Federal Regulations (14 CFR) part 39, applies to an aircraft model of which our records indicate you may be the registered owner. Airworthiness Directives affect aviation safety and are regulations which require immediate attention. You are cautioned that no person may operate an aircraft to which an Airworthiness Directive applies, except in accordance with the requirements of the Airworthiness Directive (reference 14 CFR part 39, subpart 39.3).

**2000-09-03 BOEING:** Amendment 39-11711. Docket 2000-NM-93-AD. Supersedes AD 2000-02-33, Amendment 39-11551.

Applicability: Model 747-400 series airplanes equipped with General Electric (GE) CF6-80C2 series engines, certificated in any category.

NOTE 1: This AD applies to each airplane identified in the preceding applicability provision, regardless of whether it has been modified, altered, or repaired in the area subject to the requirements of this AD. For airplanes that have been modified, altered, or repaired so that the performance of the requirements of this AD is affected, the owner/operator must request approval for an alternative method of compliance in accordance with paragraph (d) of this AD. The request should include an assessment of the effect of the modification, alteration, or repair on the unsafe condition addressed by this AD; and, if the unsafe condition has not been eliminated, the request should include specific proposed actions to address it.

**Compliance:** Required as indicated, unless accomplished previously.

To ensure the integrity of the fail safe features of the thrust reverser system by preventing possible failure modes in the thrust reverser control system that can result in inadvertent deployment of a thrust reverser during flight, accomplish the following:

## **Repetitive Functional Tests**

(a) Within 1,000 hours time-in-service after the most recent test of the center drive unit (CDU) cone brake as specified in paragraph (b)(1) of AD 94-15-05, amendment 39-8976; or within 650 hours time-in-service after the effective date of this AD; whichever occurs later: Perform a functional test to detect discrepancies of the CDU cone brake on each thrust reverser as specified in paragraph (a)(1) or (a)(2) of this AD, as applicable.

(1) For Model 747-400 series airplanes equipped with thrust reversers that have NOT been modified in accordance with Boeing Service Bulletin 747-78-2151 or a production equivalent: Perform the test in accordance with Boeing Service Bulletin 747-78A2166, Revision

1, dated October 9, 1997; or the applicable section of paragraph III.A. of the Accomplishment Instructions of Boeing Service Bulletin 747-78A2113, Revision 2, dated June 8, 1995, or Revision 3, dated September 11, 1997. Repeat the test thereafter at intervals not to exceed 650 hours time-in-service.

(2) For Model 747-400 series airplanes equipped with thrust reversers that HAVE been modified in accordance with Boeing Service Bulletin 747-78-2151 or a production equivalent: Perform the test in accordance with Appendix 1 (including Figure 1) of this AD. Repeat the test thereafter at intervals not to exceed 1,000 hours time-in-service.

NOTE 2: Accomplishment of the CDU cone brake test during production in accordance with Production Revision Record (PRR) 80452-102 prior to the effective date of this AD is considered acceptable for compliance with the initial test required by paragraph (a) of this AD.

NOTE 3: Model 747-400 series airplanes, line numbers 1061 and subsequent, equipped with GE CF6-80C2 engines, had a third locking system installed during production in accordance with Production Revision Record (PRR) 80452-102, and were not modified in accordance with Boeing Service Bulletin 747-78-2151 (which is a retrofit action for airplanes having line numbers 700 through 1060 inclusive).

### **Terminating Action**

(b) Accomplishment of the functional test of the CDU cone brake, as specified in paragraph (a) of this AD, constitutes terminating action for the repetitive tests of the CDU cone brake required by paragraph (b)(1) of AD 94-15-05.

### **Corrective Action**

(c) If any functional test required by paragraph (a) of this AD cannot be successfully performed as specified in the referenced service bulletin, or if any discrepancy is detected during any functional test required by paragraph (a) of this AD, accomplish either paragraph (c)(1) or (c)(2) of this AD.

(1) Prior to further flight, repair in accordance with Boeing Service Bulletin 747-78A2166, Revision 1, dated October 9, 1997; or Boeing Service Bulletin 747-78A2113, Revision 2, dated June 8, 1995, or Revision 3, dated September 11, 1997. Or,

(2) The airplane may be operated in accordance with the provisions and limitations specified in the operator's FAA-approved MEL, provided that no more than one thrust reverser on the airplane is inoperative.

### **Alternative Methods of Compliance**

(d) (1) An alternative method of compliance or adjustment of the compliance time that provides an acceptable level of safety may be used if approved by the Manager, Seattle Aircraft Certification Office (ACO), FAA, Transport Airplane Directorate. Operators shall submit their requests through an appropriate FAA Principal Maintenance Inspector, who may add comments and then send it to the Manager, Seattle ACO.

(2) Alternative methods of compliance approved previously in accordance with AD 2000-02-33, Amendment 39-11551, are considered to be approved as alternative methods of compliance with this AD.

NOTE 4: Information concerning the existence of approved alternative methods of compliance with this AD, if any, may be obtained from the Seattle ACO.

### **Special Flight Permits**

(e) Special flight permits may be issued in accordance with sections 21.197 and 21.199 of the Federal Aviation Regulations (14 CFR 21.197 and 21.199) to operate the airplane to a location where the requirements of this AD can be accomplished.

### **Incorporation by Reference**

(f) Except as provided by paragraphs (a)(2) and (c)(2) of this AD, the actions shall be done in accordance with Boeing Service Bulletin 747-78A2166, Revision 1, dated October 9, 1997; Boeing Service Bulletin 747-78A2113, Revision 2, dated June 8, 1995; and Boeing Service Bulletin 747-78A2113, Revision 3, dated September 11, 1997. This incorporation by reference was previously approved by the Director of the Federal Register as of March 13, 2000 (65 FR 5742, February 7, 2000). Copies may be obtained from Boeing Commercial Airplane Group, P.O. Box 3707, Seattle, Washington 98124-2207. Copies may be inspected at the FAA, Transport Airplane Directorate, 1601 Lind Avenue, SW., Renton, Washington; or at the Office of the Federal Register, 800 North Capitol Street, NW., suite 700, Washington, DC.

(g) This amendment becomes effective on May 19, 2000.

#### **FOR FURTHER INFORMATION CONTACT:**

Holly Thorson, Aerospace Engineer, Propulsion Branch, ANM-140S, FAA, Transport Airplane Directorate, Seattle Aircraft Certification Office, 1601 Lind Avenue, SW., Renton, Washington 98055-4056; telephone (425) 227-1357; fax (425) 227-1181.

Issued in Renton, Washington, on April 26, 2000.

Donald L. Riggan, Acting Manager, Transport Airplane Directorate, Aircraft Certification Service.

## APPENDIX 1.

### THRUST REVERSER CDU CONE BRAKE TEST

1. This procedure contains steps to do a check of the holding torque of the CDU cone brake.
2. CDU cone brake check (Figure 1):

A. Prepare to do the check:

- (1) Open the fan cowl panels.
- (2) Pull up on the manual release handle to unlock the electro-mechanical brake.
- (3) Pull the manual brake release lever on the CDU to release the cone brake.

**NOTE:** This will release the pre-load tension that may occur during a stow cycle.

- (4) Return the manual brake release lever to the locked position to engage the cone brake.
- (5) Remove the two bolts that hold the lockout plate to the CDU and remove the lockout plate.
- (6) Install a 1/4-inch drive and a dial-type torque wrench into the CDU drive pad.

**CAUTION:** DO NOT USE MORE THAN 100 POUND-INCHES OF TORQUE WHEN YOU DO THIS CHECK. EXCESSIVE TORQUE WILL DAMAGE THE CDU.

- (7) Turn the torque wrench to try to manually extend the translating cowl until you get at least 15 pound-inches.

**NOTE:** The cone brake prevents movement in the extend direction only. If you try to measure the holding torque in the retract direction, you will get a false reading.

- (8) If the torque is less than 15 pound-inches, you must replace the CDU.
- (9) Reinstall the lockout plate.

B. Return the airplane to its usual condition:

- (1) Fully retract the thrust reverser (unless already accomplished).
- (2) Pull down on the manual release handle on the electro-mechanical brake until the handle fully engages the retaining clip (unless already accomplished).

**NOTE:** This will lock the electro-mechanical brake.

- (3) Close the fan cowl panels.

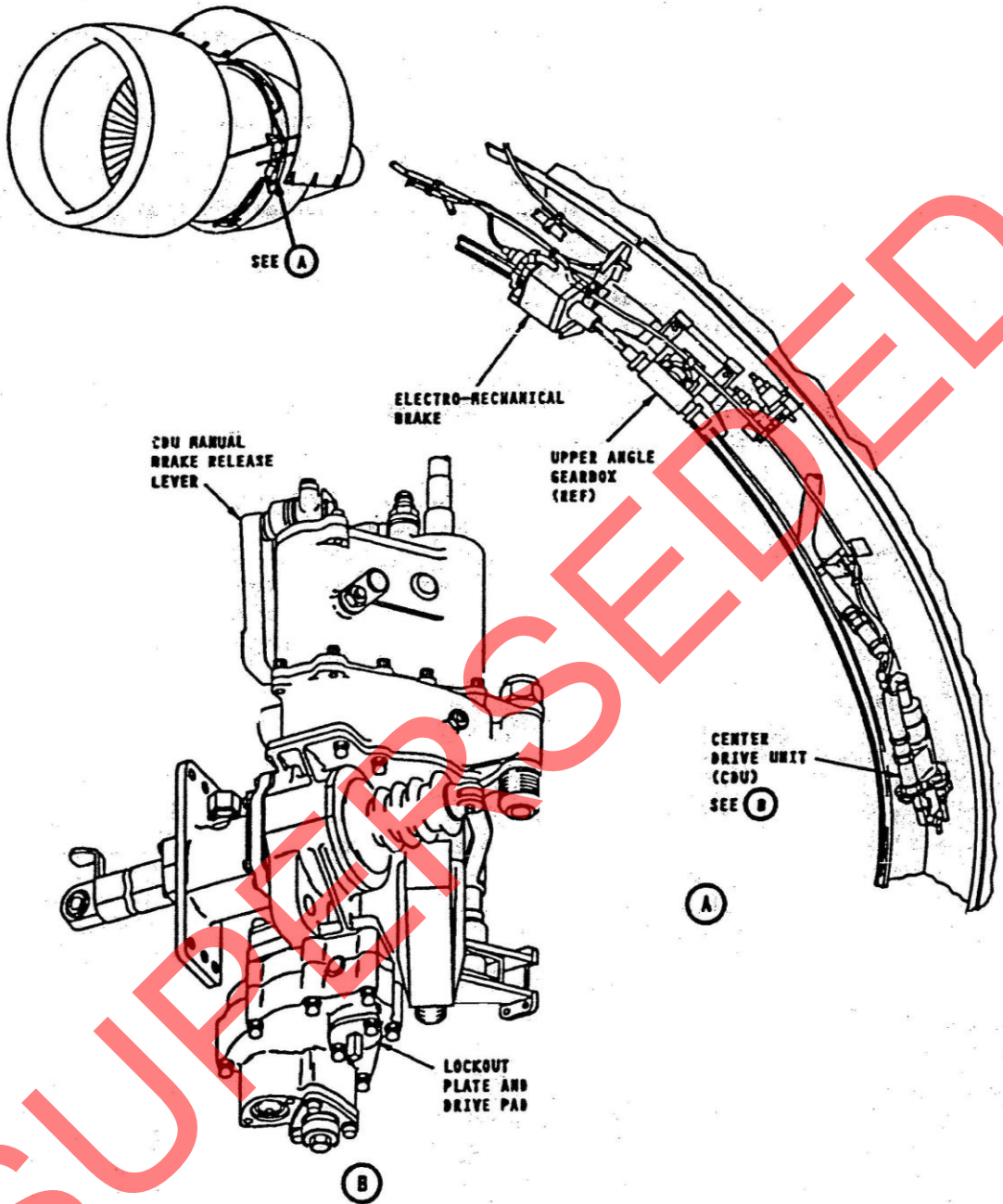

Electro-Mechanical Brake and CDU Cone Brake Torque Check  
Figure 1