

[Federal Register: February 2, 2006 (Volume 71, Number 22)]  
[Rules and Regulations]  
[Page 5581-5584]  
From the Federal Register Online via GPO Access [wais.access.gpo.gov]  
[DOCID:fr02fe06-1]

---

## DEPARTMENT OF TRANSPORTATION

### Federal Aviation Administration

#### 14 CFR Part 39

[Docket No. FAA-2005-23221; Directorate Identifier 2005-CE-51-AD; Amendment 39-14459; AD 2006-02-51]

RIN 2120-AA64

#### Airworthiness Directives; Raytheon Aircraft Company Model 390 Airplanes

**AGENCY:** Federal Aviation Administration (FAA), DOT.

**ACTION:** Final rule; request for comments.

---

**SUMMARY:** The FAA is adopting a new airworthiness directive (AD) for certain Raytheon Aircraft Company Model 390 airplanes. This AD contains the same information as emergency AD 2006-02-51 and publishes the action in the Federal Register. This AD requires you to visually inspect the hydraulic tube assembly (P/N 390-580035-0001 or P/N 390-580035-0005) and the clamp (P/N MS21919WCJ6 or P/N MS21919WCJ7) (or FAA-approved equivalent part numbers), as specified in the service information; replace the clamp at each inspection; replace the hydraulic tube assembly immediately if any of the problems identified in the service bulletin are found; and report the results of each inspection or replacement to the FAA. This AD results from failure of the hydraulic tube assembly, which caused in-flight loss of hydraulic fluid. We are issuing this AD to prevent failure of the hydraulic tube assembly and consequent leaking of hydraulic fluid. This failure could result in loss of hydraulic system functions and risk of fire because of flammable fluid leakage in the engine nacelle and lead to loss of control of the airplane.

**DATES:** This AD becomes effective on February 2, 2006. As of February 2, 2006, the Director of the Office of the Federal Register approved the incorporation by reference of certain publications listed in the regulation. We must receive any comments on this AD by March 2, 2006.

**ADDRESSES:** Use one of the following to submit comments on this AD:

- DOT Docket Web site: Go to <http://dms.dot.gov> and follow the instructions for sending your comments electronically.
- Government-wide rulemaking Web site: Go to <http://www.regulations.gov> and follow the instructions for sending your comments electronically.
- Mail: Docket Management Facility; U.S. Department of Transportation, 400 Seventh Street, SW., Nassif Building, Room PL-401, Washington, DC 20590-0001.

- Fax: 1-202-493-2251.
  - Hand Delivery: Room PL-401 on the plaza level of the Nassif Building, 400 Seventh Street, SW., Washington, DC, between 9 a.m. and 5 p.m., Monday through Friday, except Federal holidays.
- To view the comments to this AD, go to <http://dms.dot.gov>. The docket number is FAA-2005-23221; Directorate Identifier 2005-CE-51-AD.

To get the service information identified in this AD, contact Raytheon Aircraft Company, P.O. Box 85, Wichita, Kansas 67201-0085; telephone: (800) 625-7043.

**FOR FURTHER INFORMATION CONTACT:** James P. Galstad, Propulsion Aerospace Engineer, ACE 116W, Wichita Aircraft Certification Office, 1801 Airport Road, Room 100, Wichita, Kansas 67209; telephone: 316-946-4135; facsimile: 316-946-4107.

## **SUPPLEMENTARY INFORMATION:**

### **Discussion**

#### *What Events Have Caused This AD?*

The FAA received reports of four failures of the part number (P/N) 390-580035-0001 hydraulic tube assembly located on the left engine assembly of Raytheon Model 390 airplanes. The failures resulted in in-flight loss of hydraulic fluid. The tube is installed between the hydraulic pump and the hydraulic pulsation damper and carries hydraulic pump output pressure.

The latest failure occurred on an airplane with 83 hours time-in-service on the hydraulic tube assembly.

On January 19, 2006, the FAA issued emergency AD 2006-02-51 to require you to visually inspect the hydraulic tube assembly (P/N 390-580035-0001 or P/N 390-580035-0005) and the clamp (P/N MS21919WCJ6 or P/N MS21919WCJ7) (or FAA-approved equivalent part numbers), as specified in the service information; replace the clamp at each inspection; replace the hydraulic tube assembly immediately if any of the problems identified in the service bulletin are found; and report the results of each inspection or replacement to the FAA.

#### *Why Is It Important To Publish This AD?*

The FAA found that immediate corrective action was required, that notice and opportunity for prior public comment were impracticable and contrary to the public interest, and that good cause existed to make the AD effective immediately by individual letters issued on January 19, 2006, to all known U.S. operators of the affected Raytheon Aircraft Company Model 390 airplanes. These conditions still exist, and the AD is published in the Federal Register as an amendment to section 39.13 of the Federal Aviation Regulations (14 CFR 39.13) to make it effective to all persons.

### **Comments Invited**

#### *Will I Have the Opportunity To Comment Before You Issue the Rule?*

This AD is a final rule that involves requirements affecting flight safety and was not preceded by notice and an opportunity for public comment; however, we invite you to submit any written relevant data, views, or arguments regarding this AD. Send your comments to an address listed under ADDRESSES. Include the docket number, "FAA-2005-23221; Directorate Identifier 2005-CE-51-AD" at the beginning of your comments. We will post all comments we receive, without change, to <http://dms.dot.gov>, including any personal information you provide. We will also post a report summarizing each substantive verbal contact with FAA personnel concerning this AD.

Using the search function of our docket Web site, anyone can find and read the comments received into any of our dockets, including the name of the individual who sent the comment (or signed the comment on behalf of an association, business, labor union, etc.). This is docket number FAA-2005-23221; Directorate Identifier 2005-CE-51-AD. You may review the DOT's complete Privacy Act Statement in the Federal Register published on April 11, 2000 (65 FR 19477-78) or you may visit <http://dms.dot.gov>.

*Are There Any Specific Portions of This AD I Should Pay Attention To?*

We specifically invite comments on the overall regulatory, economic, environmental, and energy aspects of this AD. If you contact us through a nonwritten communication and that contact relates to a substantive part of this AD, we will summarize the contact and place the summary in the docket. We will consider all comments received by the closing date and may amend this AD in light of those comments and contacts.

**Docket Information**

*Where Can I Go To View the Docket Information?*

You may view the AD docket that contains the AD, any comments received, and any final disposition in person at the DMS Docket Offices between 9 a.m. and 5 p.m. (eastern standard time), Monday through Friday, except Federal holidays. The Docket Office (telephone 1-800-647-5227) is located on the plaza level of the Department of Transportation NASSIF Building at the street address stated in ADDRESSES. You may also view the AD docket on the Internet at <http://dms.dot.gov>. The comments will be available in the AD docket shortly after the DMS receives them.

**Authority for This Rulemaking**

*What Authority Does FAA Have for Issuing This Rulemaking Action?*

Title 49 of the United States Code specifies the FAA's authority to issue rules on aviation safety. Subtitle I, Section 106 describes the authority of the FAA Administrator. Subtitle VII, Aviation Programs, describes in more detail the scope of the agency's authority.

We are issuing this rulemaking under the authority described in Subtitle VII, Part A, Subpart III, Section 44701, "General requirements." Under that section, Congress charges the FAA with promoting safe flight of civil aircraft in air commerce by prescribing regulations for practices, methods, and procedures the Administrator finds necessary for safety in air commerce. This regulation is within the scope of that authority because it addresses an unsafe condition that is likely to exist or develop on products identified in this AD.

**Regulatory Findings**

*Will This AD Impact Various Entities?*

We have determined that this AD will not have federalism implications under Executive Order 13132. This AD will not have a substantial direct effect on the States, on the relationship between the national government and the States, or on the distribution of power and responsibilities among the various levels of government.

*Will This AD Involve a Significant Rule or Regulatory Action?*

For the reasons discussed above, I certify that this AD:

1. Is not a "significant regulatory action" under Executive Order 12866;
2. Is not a "significant rule" under the DOT Regulatory Policies and Procedures (44 FR 11034, February 26, 1979); and
3. Will not have a significant economic impact, positive or negative, on a substantial number of small entities under the criteria of the Regulatory Flexibility Act.

We prepared a summary of the costs to comply with this AD (and other information as included in the Regulatory Evaluation) and placed it in the AD Docket. You may get a copy of this summary by sending a request to us at the address listed under ADDRESSES. Include "Docket No. FAA-2005-23221; Directorate Identifier 2005-CE-51-AD" in your request.

**List of Subjects in 14 CFR Part 39**

Air transportation, Aircraft, Aviation safety, Incorporation by reference, Safety.

**Adoption of the Amendment**

Accordingly, under the authority delegated to me by the Administrator, the Federal Aviation Administration amends part 39 of the Federal Aviation Regulations (14 CFR part 39) as follows:

**PART 39—AIRWORTHINESS DIRECTIVES**

1. The authority citation for part 39 continues to read as follows:

Authority: 49 U.S.C. 106(g), 40113, 44701.

**§ 39.13 [Amended]**

2. The FAA amends § 39.13 by adding the following new airworthiness directive (AD):

# AIRWORTHINESS DIRECTIVE



Aircraft Certification Service  
Washington, DC

U.S. Department  
of Transportation  
**Federal Aviation  
Administration**

[www.faa.gov/aircraft/safety/alerts/](http://www.faa.gov/aircraft/safety/alerts/)

The following Airworthiness Directive issued by the Federal Aviation Administration in accordance with the provisions of Title 14 of the Code of Federal Regulations (14 CFR) part 39, applies to an aircraft model of which our records indicate you may be the registered owner. Airworthiness Directives affect aviation safety and are regulations which require immediate attention. You are cautioned that no person may operate an aircraft to which an Airworthiness Directive applies, except in accordance with the requirements of the Airworthiness Directive (reference 14 CFR part 39, subpart 39.3).

**2006-02-51 Raytheon Aircraft Company:** Amendment 39-14459; Docket No. FAA-2005-23221; Directorate Identifier 2005-CE-51-AD.

## When Does This AD Become Effective?

- (a) This AD becomes effective on February 2, 2006.

## Are Any Other ADs Affected by This Action?

- (b) None.

## What Airplanes Are Affected by This AD?

- (c) This AD affects the following Model 390 airplanes that are certificated in any category:
  - (1) Serial numbers RB-1 through RB-49 that are equipped with Kit 390-9100 that incorporates part number (P/N) 390-580035-0001 (or FAA-approved equivalent part number);
  - (2) Serial numbers RB-50 through RB-141; and
  - (3) Serial numbers RB-143 through RB-148.

## What Is the Unsafe Condition Presented in This AD?

- (d) This AD is the result of failure of the hydraulic tube assembly, which caused in-flight loss of hydraulic fluid. We are issuing this AD to prevent failure of the hydraulic tube assembly and the clamp and consequent leaking of hydraulic fluid. This failure could result in loss of hydraulic system functions and risk of fire because of flammable fluid leakage in the engine nacelle and lead to loss of control of the airplane.

## What Must I Do To Address This Problem?

- (e) To address this problem, you must do the following:

| Actions  | Compliance  | Procedures  |
|--|---|---|
| <p>(1) Perform a one-time visual inspection of the hydraulic tube assembly and clamp using Raytheon Safety Communique No. 267, dated January 2006. Perform repetitive detailed inspections thereafter per Raytheon Mandatory Service Bulletin No. SB 29-3771, dated January, 2006.</p> <p>(i) The tube assembly part number is P/N 390-580035-0001 or P/N 390-580035-0005).</p> <p>(ii) The clamp part number is P/N MS21919WCJ6 or P/N MS21919WCJ7.</p> | <p>Visually inspect before further flight after February 2, 2006 (the effective date of this AD), except for those who received emergency AD 2006-02-51, issued January 19, 2006, unless already done. Perform the detailed inspection within 10 hours time-in-service (TIS) after February 2, 2006 (the effective date of this AD), except for those who received emergency AD 2006-02-51, issued January 19, 2006, unless already done. Inspect thereafter at intervals not to exceed 50 hours TIS. You may perform the detailed inspection before further flight instead of the visual inspection. Emergency AD 2006-02-51 contained the requirements of this amendment and became effective immediately upon receipt.</p> | <p>For the visual inspection, use Raytheon Safety Communique No. 267, dated January, 2006. For the detailed inspections, use the procedures in Raytheon Mandatory Service Bulletin No. SB 29-3771, dated January, 2006.</p> |
| <p>(2) Replace the hydraulic tube assembly (P/N 390-580035-0001 or P/N 390-580035-0005) and the clamp (P/N MS21919WCJ6 or P/N MS21919WCJ7) (or FAA-approved equivalent part numbers) with new P/N 390-580035-0001 or P/N 390-580035-0005 and P/N MS21919WCJ7 (or FAA-approved equivalent part numbers) or used parts.</p>  | <p>Replace the clamp at each inspection. Replace the tube assembly prior to further flight after any inspection where evidence of chafing, excessive vibration, wear, deterioration, or hydraulic fluid leakage is found. Refer to SB 29-3771, dated January, 2006 for acceptance/rejection information for the tube assembly.</p>  | <p>Follow the procedures in Raytheon Mandatory Service Bulletin No. SB 29-3771, dated January, 2006.</p>  |

| Actions   | Compliance   | Procedures  |
|---|--|---|
| (3) Report the results to FAA of each inspection or replacement required in paragraphs (e)(1) and (e)(2) of this AD. The Office of Management and Budget (OMB) approved the information collection requirements contained in this regulation under the provisions of the Paperwork Reduction Act of 1980 (44 U.S.C. 3501 and those following sections) and assigned OMB Control Number 2120-0056. | Within 10 days after the inspection or replacement or within 10 days after February 2, 2006 (the effective date of this AD), except for those who received emergency AD 2006-02-51, issued January 19, 2006, whichever occurs later. | Include in your report the airplane serial number, the TIS of the airplane, and the TIS of the hydraulic tube assembly (P/N 390-580035-0001 or P/N 390-580035-0005) (or FAA-approved equivalent part number). E-mail/send your report to James P. Galstad, Propulsion Aerospace Engineer, ACE 116W, Wichita Aircraft Certification Office, 1801 Airport Road, Room 100, Wichita, Kansas 67209; e-mail: <a href="mailto:james.galstad@faa.gov">james.galstad@faa.gov</a> ; telephone: 316-946-4135; facsimile: 316-946-4107. |

(4) Repositioning and Special Flight Permits: You may operate the airplane to return/position the airplane to a home base, hangar, maintenance facility, etc., for the purpose of doing only the visual inspection required by this AD.

(i) Operation of up to 10 hours time-in-service (TIS) is allowed for visual inspection repositioning flight(s) provided the flight(s) occur(s) no later than 30 days after January 19, 2006. This is a one-time provision.

(ii) Special flight permits are also allowed for the visual inspection required for this AD. Use the procedures in 14 CFR part 39.

(iii) Special flight permits are prohibited for the detailed inspections and possible replacements required by this AD.

(iv) For any repositioning flight or special flight permit for the visual inspection, you must operate with only the PILOT AND ANY ADDITIONAL FLIGHT CREW MEMBER REQUIRED FOR SAFE OPERATION.

(5) Disposal of Parts: Return replaced hydraulic tube assembly (P/N 390-580035-0001 or P/N 390-580035-0005) to Raytheon Aircraft Company per SB 29-3771 and dispose of the P/N MS21919WCJ6 or P/N MS21919WCJ6 clamp (or FAA-approved equivalent part numbers) following 14 CFR 43.10. Ship any replaced hydraulic tube and dispose of the clamp prior to returning the aircraft to service.

(6) Parts Manufacturer Approval (PMA): 14 CFR 21.303 allows for replacement parts through PMA. The phrase "or FAA-approved equivalent part number(s)" in this AD is intended to signify those parts that are PMA approved through identity to the design of the part under the type certificate and replacement parts to correct the unsafe condition under PMA (other than identity). If parts are installed that are identical to the unsafe parts, then the corrective actions of the AD affect these parts also. In addition, equivalent replacement parts to correct the unsafe condition under PMA (other than identity) may also be installed provided they meet current airworthiness standards, which include those actions cited in this AD.

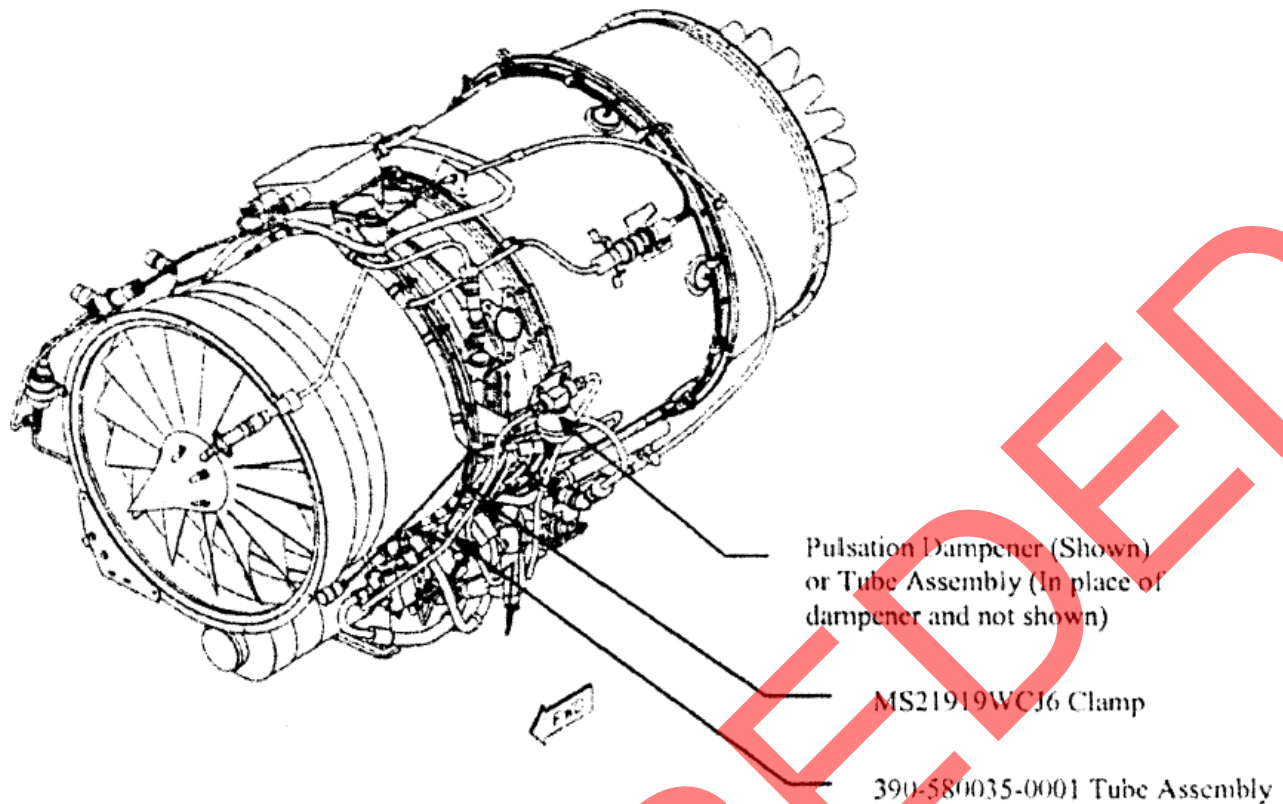

Figure 1. Hydraulic Tube Assembly with Clamp on Left Hand Engine.

**May I Request an Alternative Method of Compliance?**

(f) You may request a different method of compliance or a different compliance time for this AD by following the procedures in 14 CFR 39.19. Unless FAA authorizes otherwise, send your request to your principal inspector. The principal inspector may add comments and will send your request to the Manager, Wichita Aircraft Certification Office, FAA. For information on any already approved alternative methods of compliance, contact James P. Galstad, Propulsion Aerospace Engineer, ACE 116W, Wichita Aircraft Certification Office, 1801 Airport Road, Room 100, Wichita, Kansas 67209; telephone: 316-946-4135; facsimile: 316-946-4107.

**Does This AD Incorporate Any Material by Reference?**

(g) You must do the actions required by this AD following the instructions in Raytheon Mandatory Service Bulletin No. SB 29-3771, dated January, 2006; and Raytheon Safety Communique No. 267, dated January 2006. The Director of the Federal Register approved the incorporation by reference of this service information in accordance with 5 U.S.C. 552(a) and 1 CFR part 51. To get a copy of this service information, contact Raytheon Aircraft Company, P.O. Box 85, Wichita, Kansas 67201-0085; telephone: (800) 625-7043. To review copies of this service information, go to the National Archives and Records Administration (NARA). For information on the availability of this material at NARA, go to: [http://www.archives.gov/federal\\_register/code\\_of\\_federal\\_regulations/ibr\\_locations.html](http://www.archives.gov/federal_register/code_of_federal_regulations/ibr_locations.html) or call (202) 741-6030. To view the AD docket, go to the Docket Management Facility; U.S. Department of

Transportation, 400 Seventh Street, SW., Nassif Building, Room PL-401, Washington, DC 20590-001 or on the Internet at <http://dms.dot.gov>. The docket number is FAA-2005-23221; Directorate Identifier 2005-CE-51-AD.

Issued in Kansas City, Missouri, on January 26, 2006.

David R. Showers,

Acting Manager, Small Airplane Directorate, Aircraft Certification Service.

[FR Doc. 06-921 Filed 2-1-06; 8:45 am]

BILLING CODE 4910-13-P

SUPERSEDED