

DEPARTMENT OF TRANSPORTATION

Federal Aviation Administration

14 CFR Part 39

[Docket No. FAA-2013-0486; Directorate Identifier 2010-SW-031-AD; Amendment 39-17622; AD 2013-20-16]

RIN 2120-AA64

Airworthiness Directives; MD Helicopters, Inc. (MDHI) Helicopters

AGENCY: Federal Aviation Administration (FAA), DOT.

ACTION: Final rule.

SUMMARY: We are adopting a new airworthiness directive (AD) for MDHI Model MD900 helicopters with certain main rotor blade (MRB) retention bolts (bolts) installed. This AD requires a daily check of the position of each bolt, a daily check and a repetitive inspection for a gap in each bolt, and, if necessary, removing and inspecting the bolt for a crack and replacing any cracked bolt with an airworthy bolt. This AD was prompted by multiple reports of in-service bolt failures. The actions are intended to prevent failure of a bolt, which could lead to loss of MRB structural integrity and subsequent loss of control of the helicopter.

DATES: This AD is effective December 5, 2013.

ADDRESSES: For service information identified in this AD, contact MDHI, Attn: Customer Support Division, 4555 E. McDowell Rd., Mail Stop M615, Mesa, AZ 85215-9734, telephone (800) 388-3378, fax (480) 346-6813, or at <http://www.mdhelicopters.com>. You may review a copy of the referenced service information at the FAA, Office of the Regional Counsel, Southwest Region, 2601 Meacham Blvd., Room 663, Fort Worth, Texas 76137.

Examining the AD Docket

You may examine the AD docket on the Internet at <http://www.regulations.gov> or in person at the Docket Operations Office between 9 a.m. and 5 p.m., Monday through Friday, except Federal holidays. The AD docket contains this AD, the economic evaluation, any comments received, and other information. The street address for the Docket Operations Office (phone: 800-647-5527) is U.S. Department of Transportation, Docket Operations Office, M-30, West Building Ground Floor, Room W12-140, 1200 New Jersey Avenue SE., Washington, DC 20590.

FOR FURTHER INFORMATION CONTACT: Roger Durbin, Aerospace Engineer, FAA, Los Angeles Aircraft Certification Office, Airframe Branch, ANM-120L, 3960 Paramount Blvd., Lakewood, CA 90712, telephone (562) 627-5233, fax (562) 627-5210, email roger.durbin@faa.gov.

SUPPLEMENTARY INFORMATION:

Discussion

On June 14, 2013, at 78 FR 35773, the Federal Register published our notice of proposed rulemaking (NPRM), which proposed to amend 14 CFR part 39 to add an AD that would apply to MDHI Model MD900 helicopters with certain bolts installed. The NPRM proposed to require a daily check of the position of each bolt, a daily check and a repetitive inspection for a gap in each bolt, and, if necessary, removing and inspecting the bolt for a crack and replacing any cracked bolt with an airworthy bolt. The NPRM was prompted by multiple reports of in-service bolt failures. The proposed requirements were intended to prevent failure of a bolt, which could lead to loss of MRB structural integrity and subsequent loss of control of the helicopter.

Comments

We gave the public the opportunity to participate in developing this AD, but we did not receive any comments on the NPRM (78 FR 35773, June 14, 2013).

FAA's Determination

We have reviewed the relevant information and determined that an unsafe condition exists and is likely to exist or develop on other helicopters of the same type designs and that air safety and the public interest require adopting the AD requirements as proposed.

Related Service Information

MDHI issued Alert Service Bulletin SB900-116R1, dated April 9, 2010 (ASB SB900-116R1), which supersedes ASB SB900-116, dated February 24, 2010 (ASB SB900-116).

ASB SB900-116 specifies a repetitive check of the blade retention bolts, part number (P/N) 900R3100001-103 and 900R3100001-105, for a gap and, depending on the outcome of the inspection, removing and inspecting the bolt for damage. The ASB also specifies a repetitive force check of each bolt, P/N 900R3100001-103, and a torque check of each bolt, P/N 900R3100001-105. Lastly, the ASB specifies a daily preflight check of each bolt to examine the position of the bolt and for a gap, and, if any bolt has moved up or down or if there was no gap, removing and inspecting the bolt.

Superseding ASB SB900-116R1 retains the same specifications as ASB SB90016, except that it revises the interval for the bolt force and torque checks from 4-6 flight-hours to 8-10 flight-hours. ASB SB90016R1 also revises the change of force or torque from not more than 10 percent to not more than 10 percent.

Differences Between This AD and the Service Information

This AD uses the term "inspect" when describing the action of inspecting a bolt for a crack and inspecting for a gap between the thrust washer and the retainer. The ASB uses the term "check."

Costs of Compliance

We estimate that this AD will affect 29 helicopters in the U.S. registry. We estimate that operators may incur the following costs to comply with this AD: The average labor rate is \$85 per work hour. It will take about .5 work hour to do a gap inspection of each bolt. It will take about 1 work hour to replace a cracked bolt and the required parts will cost \$800 at a total cost per helicopter of \$928.

Authority for This Rulemaking

Title 49 of the United States Code specifies the FAA's authority to issue rules on aviation safety. Subtitle I, section 106, describes the authority of the FAA Administrator. Subtitle VII: Aviation Programs, describes in more detail the scope of the Agency's authority.

We are issuing this rulemaking under the authority described in Subtitle VII, Part A, Subpart III, Section 44701: "General requirements." Under that section, Congress charges the FAA with promoting safe flight of

civil aircraft in air commerce by prescribing regulations for practices, methods, and procedures the Administrator finds necessary for safety in air commerce. This regulation is within the scope of that authority because it addresses an unsafe condition that is likely to exist or develop on products identified in this rulemaking action.

Regulatory Findings

This AD will not have federalism implications under Executive Order 13132. This AD will not have a substantial direct effect on the States, on the relationship between the national government and the States, or on the distribution of power and responsibilities among the various levels of government.

For the reasons discussed above, I certify that this AD:

- (1) Is not a "significant regulatory action" under Executive Order 12866;
- (2) Is not a "significant rule" under DOT Regulatory Policies and Procedures (44 FR 11034, February 26, 1979);
- (3) Will not affect intrastate aviation in Alaska to the extent that it justifies making a regulatory distinction; and
- (4) Will not have a significant economic impact, positive or negative, on a substantial number of small entities under the criteria of the Regulatory Flexibility Act.

We prepared an economic evaluation of the estimated costs to comply with this AD and placed it in the AD docket.

List of Subjects in 14 CFR Part 39

Air transportation, Aircraft, Aviation safety, Incorporation by reference, Safety.

Adoption of the Amendment

Accordingly, under the authority delegated to me by the Administrator, the FAA amends 14 CFR part 39 as follows:

PART 39—AIRWORTHINESS DIRECTIVES

1. The authority citation for part 39 continues to read as follows:

Authority: 49 U.S.C. 106(g), 40113, 44701.

§ 39.13 [Amended]

2. The FAA amends § 39.13 by adding the following new airworthiness directive (AD):



2013-20-16 MD Helicopters, Inc. (MDHI): Amendment 39-17622; Docket No. FAA-2013-0486; Directorate Identifier 2010-SW-031-AD.

(a) Applicability

This AD applies to Model MD 900 helicopters with a main rotor blade retention bolt (bolt), part number (P/N) 900R3100001-103 or 900R3100001-105, installed; certificated in any category.

(b) Unsafe Condition

This AD defines the unsafe condition as bolt failure. This condition could result in loss of main rotor blade structural integrity and subsequent loss of control of the helicopter.

(c) Effective Date

This AD becomes effective December 5, 2013.

(d) Compliance

You are responsible for performing each action required by this AD within the specified compliance time unless it has already been accomplished prior to that time.

(e) Required Actions

(1) Before the first flight of each day:

(i) Visually check each bolt for failure. Failure of a bolt may be indicated by movement of the bolt out of the bolt hole or by inconsistent extension of the bolt above or below the other bolts being inspected (a failed bolt migrates out of the bolt hole).

(ii) Visually check for a gap between the thrust washer and the retainer, P/N 900R2100009-101 or -103. The thrust washer is depicted as item 2 and the retainer is depicted as item 8 in Figure 1 to paragraph (e) of this AD.

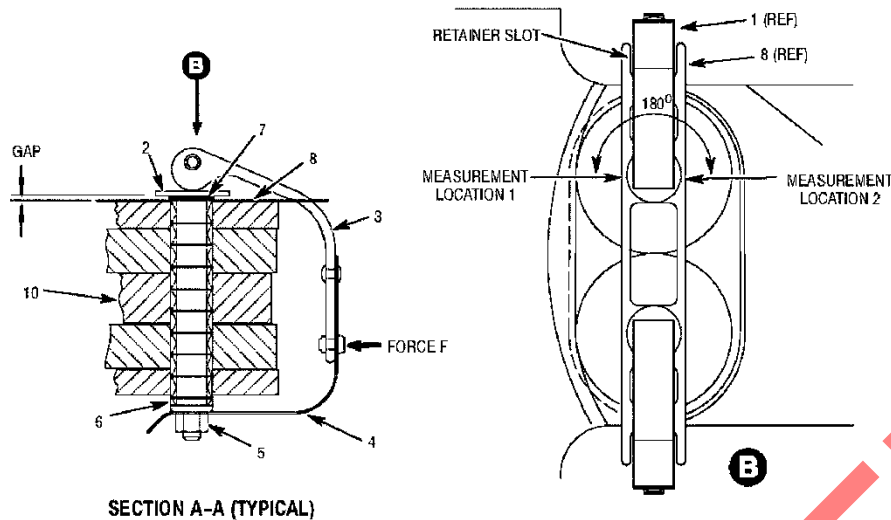

SECTION A-A (TYPICAL)

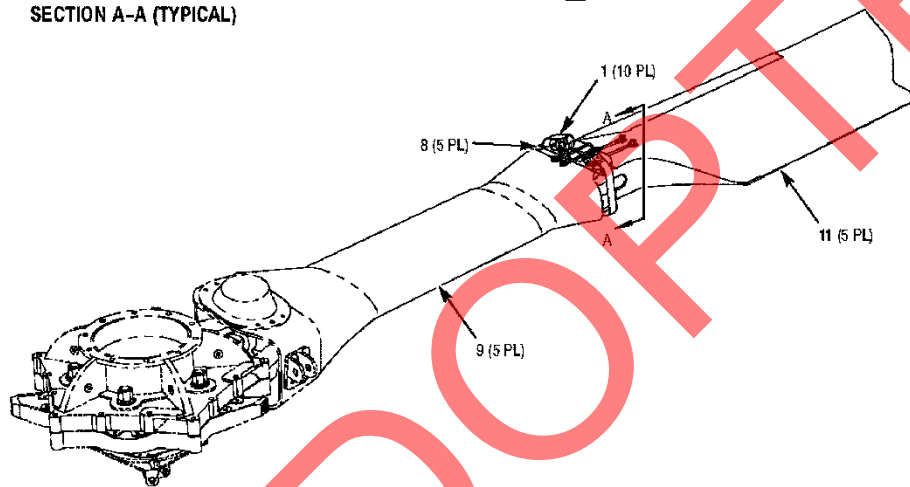

1. BLADE RETENTION BOLT
2. THRUST WASHER
3. CAM HANDLE
4. SPRING CLIP
5. HEX NUT
6. LOCK RING
7. O-RING
8. RETAINER
9. PITCHCASE
10. FLEXBEAM
11. MAIN ROTOR BLADE

Figure 1 to Paragraph (e)
Gap and Force Check of the Blade Retention Bolts

(iii) The actions required by paragraphs (e)(1)(i) and (e)(1)(ii) may be performed by the owner/operator (pilot) holding at least a private pilot certificate and must be entered into the aircraft maintenance records showing compliance with this AD in accordance with 14 CFR 43.9(a)(1)-(4) and 14 CFR 91.417(a)(2)(v). The record must be maintained as required by 14 CFR 91.417, 121.380, or 135.439.

(iv) If there is any indication of bolt failure or if there is no gap between the thrust washer and retainer, before further flight, remove and inspect the bolt for a crack. Replace any cracked bolt with an airworthy bolt.

(2) Within 300 hours time-in-service (TIS), and thereafter at intervals not to exceed 300 hours TIS, inspect each bolt for a gap between the thrust washer and the retainer.

(i) Determine whether an O-ring is installed. Install any missing O-ring.

(ii) If there is no gap between the thrust washer and retainer, before further flight, remove and inspect the bolt for a crack. Replace any cracked bolt with an airworthy bolt.

(iii) If there is a gap between the thrust washer and retainer, measure the gap in two locations, 180 degrees apart, with a feeler gage. If the gap is more than 0.100 inch (2.54 mm) at either location, before further flight, remove and inspect the bolt for a crack. Replace any cracked bolt with an airworthy bolt.

(f) Alternative Methods of Compliance (AMOCs)

(1) The Manager, Los Angeles Aircraft Certification Office, Airframe Branch (ANM-120L), FAA, may approve AMOCs for this AD. Send your request to Roger Durbin, Aerospace Engineer, FAA, Los Angeles Aircraft Certification Office, Airframe Branch, ANM-120L, 3960 Paramount Blvd., Lakewood, CA 90712, telephone (562) 627-5233, fax (562) 627-5210, email roger.durbin@faa.gov.

(2) For operations conducted under a 14 CFR part 119 operating certificate or under 14 CFR part 91, subpart K, we suggest that you notify your principal inspector or lacking a principal inspector, the manager of the local flight standards district office or certificate holding district office before operating any aircraft complying with this AD through an AMOC.

(g) Additional Information

MDHI Alert Service Bulletin SB900-116R1, dated April 9, 2010, which supersedes MDHI Alert Service Bulletin SB SB900-116, dated February 24, 1010, neither of which is incorporated by reference, contains additional information about the subject of this AD. For service information identified in this AD, contact MDHI, Attn: Customer Support Division, 4555 E. McDowell Rd., Mail Stop M615, Mesa, AZ 85215-9734, telephone (800) 388-3378, fax (480) 346-6813, or at <http://www.mdhelicopters.com>. You may review copies of the service information at the FAA, Office of the Regional Counsel, Southwest Region, 2601 Meacham Blvd., Room 663, Fort Worth, Texas.

(h) Subject

Joint Aircraft System Component: 6210: Main rotor blade retention bolts.

Issued in Fort Worth, Texas, on September 27, 2013.

Lance T. Gant,
Acting Directorate Manager, Rotorcraft Directorate,
Aircraft Certification Service.