



SUBJ: WING SPAR, Verification of Correct Washers used with Wing Spar Attach Bolts

SAIB: AIR-21-07

Date: March 30, 2021

This is information only. Recommendations aren't mandatory.

Introduction

This Special Airworthiness Information Bulletin requests that owners verify the correct washer style prior to the installation of wing spar attach bolts when complying with AD 2020-26-16.

At this time, the airworthiness concern is not an unsafe condition that would warrant airworthiness directive (AD) action under Title 14 of the Code of Federal Regulations (14 CFR) part 39.

Background

AD 2020-26-16 requires the replacement of four wing spar attach bolts following eddy current inspection of the subject bolt holes. Although not required by the AD, it is common practice to install new washers with the new bolts. Some of the washers listed in the various model Illustrated Parts Catalogs (IPCs) for the wing spar attach bolts are designed with rounded edges on one side intended to provide additional clearance between the washer and the wing spar structure. These washers are normally used in conjunction with flat washers but are placed with the rounded side against the spar surface in locations where structural clearance cannot be maintained by the use of a flat washer. Piper Aircraft, Inc. (Piper) has made the FAA aware of recent shipments of incorrectly manufactured washers. Even though the washers may be identified with the part number that matches the IPC washer part number, the incorrect washers were manufactured without the rounded edges on one side. Installation of a non-rounded “flat” washer where a rounded washer is intended may decrease or eliminate the clearance between the washer and the spar structure.

Recommendations

The FAA recommends that any owner/operator ordering and receiving Piper part number 96352-003 (Piper purchase order code 494-284) washers for use in the wing spar attach bolts of any aircraft applicable to AD 2020-26-16 verify that those washers have the required radius on one surface. If the washers do not have the radius as shown below, do not install the wing spar attach bolts until the correct washers are obtained.

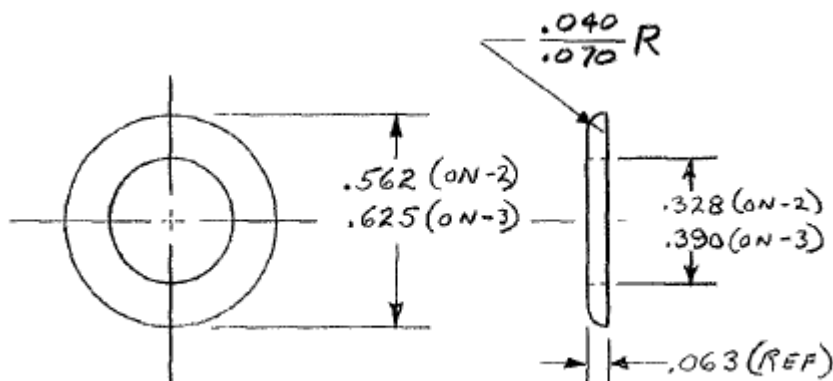

Piper Washer P/N 96352

For Further Information Contact

Dan McCully, Aerospace Engineer, 1701 Columbia Ave, College Park, GA 30337, United States;
e-mail: william.mccully@faa.gov.