

APPROVED

SSJ Program Chief Designer –
Deputy Vice-President for Development

V.N. Lavrov

2017

«02» / 03

DECISION NO. RRJ0000-OR-470-7229

for replacement of the bolts providing the reduced tightness in the connection joint of the attachment mounts with the horizontal stabilizer hinge bracket on the RRJ-95 aircraft

This Decision was developed based on the results of the Airworthiness Directive No. 2016-322-03 dated 28.12.2016 on the cracks monitoring in the lugs of upper and lower attachment mounts of horizontal stabilizer hinge brackets on the RRJ-95 aircraft in service.

Taking into consideration that the crack formation is connected with the off-design stresses, produced by total interference when bushing pressing 18-22-20-15Khim.Pas. OST 1 11125-73 into the lugs, hollow bolt T7.92.3100.077.000.73 in the bushings 18-22-20-15- Khim.Pas. OST 1 11125-73 and bolt T7.92.3100.078.000.73 in the hollow bolt T7.92.3100.077.000.73, with the purpose of crack exclusion, it is recommended to reduce the interference and to change the material of the attachment mounts.

To prevent the cracks formation in the attachment mounts T7.92.3100.141.001/002.73, T7.92.3100.142.001/002.73, T7.92.3100.143.001/002.73, T7.92.3100.144.001/002.73 the following decision is taken

DECISION:

1. In order to increase the interval of the periodical inspections the following activities to reduce the interference are performed:

1.1. On the next scheduled periodic maintenance check, to replace the hollow bolts T7.92.3100.077.000.73 to hollow bolts T7.92.3100.177.000.73 according to the procedure given in the attachment to this Decision. Following the replacement of the complete set of bolts (4 pcs.), to make a record in the Section 13 of the A/C Logbook: "Hollow bolts T7.92.3100.077.000.73 were replaced with the bolts T7.92.3100.177.000.73 in amount of 4 pcs."

Note: on the previously replaced attachment mounts, no activities for the hollow bolts T7.92.3100.077.000.73 replacement to T7.92.3100.177.000.73 are required.

Following the replacement of the hollow bolts T7.92.3100.077.000.73 complete set (4 pcs.) to the bolts T7.92.3100.177.000.73, it is necessary to perform special detailed inspection of the lugs of the attachment mounts of horizontal stabilizer hinge brackets according to the AMM 55-16-00-250-801 and instrumental inspection using the eddy current method according to the NDTM 55-16-09-001 or other methods of the

instrumental inspection, that allow to detect cracks in the material, every 100 days / 750FH (whichever comes earlier) (from the moment of Operator notification, starting from the next maintenance check) providing the results recording including photos.

The works according to this Decision are to be performed until the SB RRJ-55-00348-БД “Stabilizers – modification of the horizontal stabilizer attach fittings” with the change of the material of the attachment mounts.

Attachment 1: Procedure for hollow bolts T7.92.3100.077.000.73 replacement to the bolts T7.92.3100.177.000.73 on 16 pages.

Head of Scientific Research Division –
Deputy Chief Designer
For airframe design

K. A. Kolesov

Head of Strength Scientific Research Division –
Deputy Chief Designer for strength

V. H. Sahin
Mitschshov

Head of Operational and Maintenance documentation
Elaboration Scientific Research Division

M. N. Shmonin

Head of Customer Care Center

D. A. Omelchenko

**Procedure for
replacement of T7.92.3100.077.000.73 hollow bolts to T7.92.3100.177.000.73 bolts**

**Procedure for
replacement of T7.92.3100.077.000.73 hollow bolts to
T7.92.3100.177.000.73 bolts**

This Procedure contains the technique for the modification of the stabilizer left panel. The modification of the stabilizer right panel is the same as for the left one.

Demounting along the upper hinge fitting of the stabilizer

- (1) Demounting of the hollow bolt (T7.92.3100.077.000.73) along the upper hinge fitting of the stabilizer (see Fig. 1).
 - (a) Clean the surfaces of the upper cap from dirt with cleaning rags dampened with НЕФРАС-C2-80/120 solvent if necessary.
 - (б) Remove the 22,5x32.2.11 ГОСТ 397-79 splint and discard it.
 - (в) Remove the 14-Хим.Пас-ОСТ 1 33049-80 nut of the upper cap attachment to the fitting of the stabilizer. Save the nut for the further installation
 - (г) Remove 1,5-14-25-Хим.Пас-ОСТ 1 34508-80 washer and save it for the further installation.
 - (д) Remove the bolt (T7.92.3100.078.000.73) and save it for the further installation.
 - (е) Carefully remove the bolt-bushing (T7.92.3100.077.000.73) from the lugs of the upper cap. Discard the bolt-bushing.
 - (ж) Remove 2-20-32-Хим.Пас-ОСТ 1 34508-80 washer and save it for the further installation.

Procedure for
replacement of T7.92.3100.077.000.73 hollow bolts to T7.92.3100.177.000.73 bolts

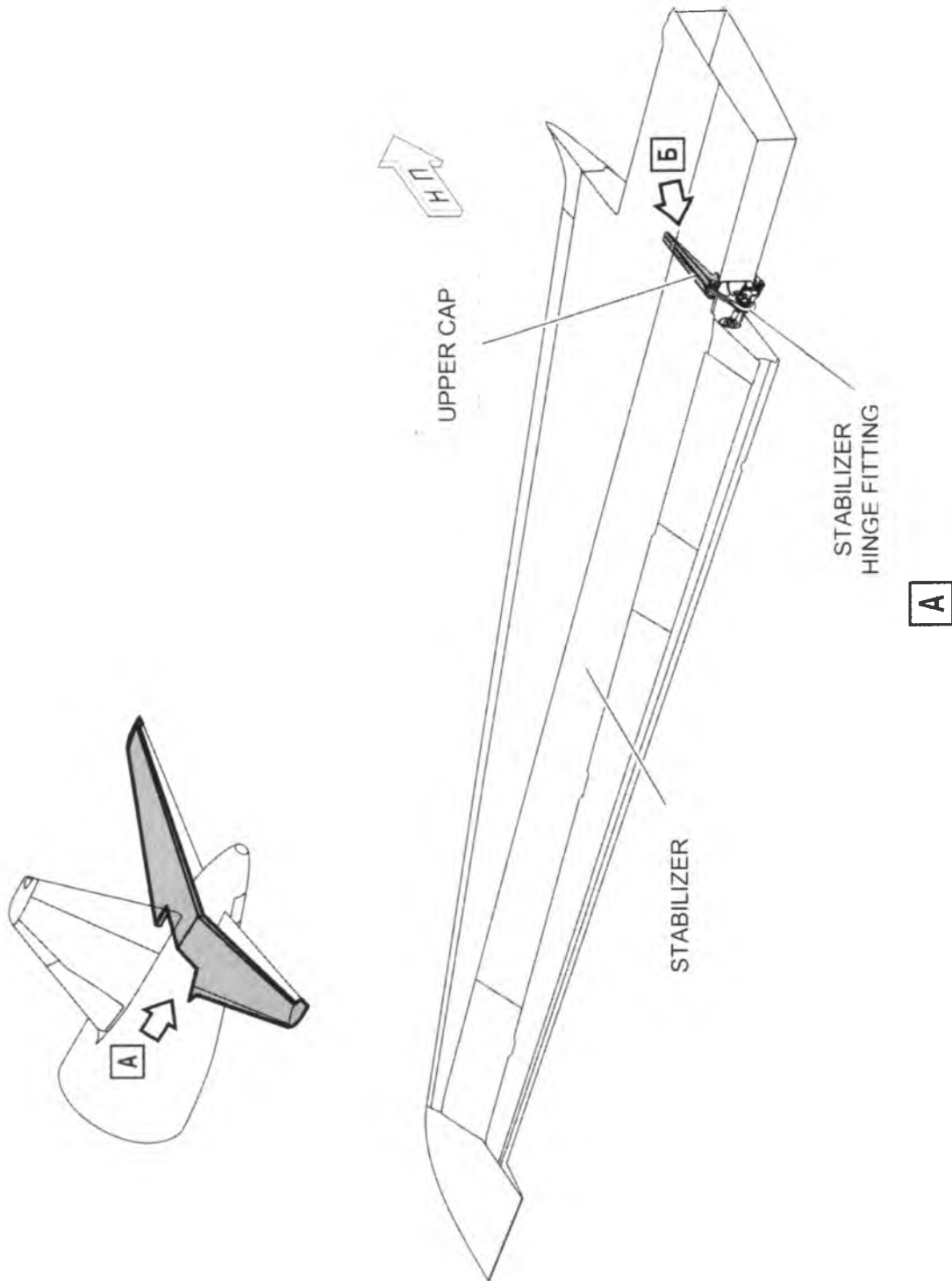

ITK_RRJ_SB_55_11_00348_008_A01_R

Demounting of the hollow bolts (T7.92.3100.077.000.73) along the upper hinge fitting
of the stabilizer
Figure 1 (sheet 1 of 3)

Procedure for
replacement of T7.92.3100.077.000.73 hollow bolts to T7.92.3100.177.000.73 bolts

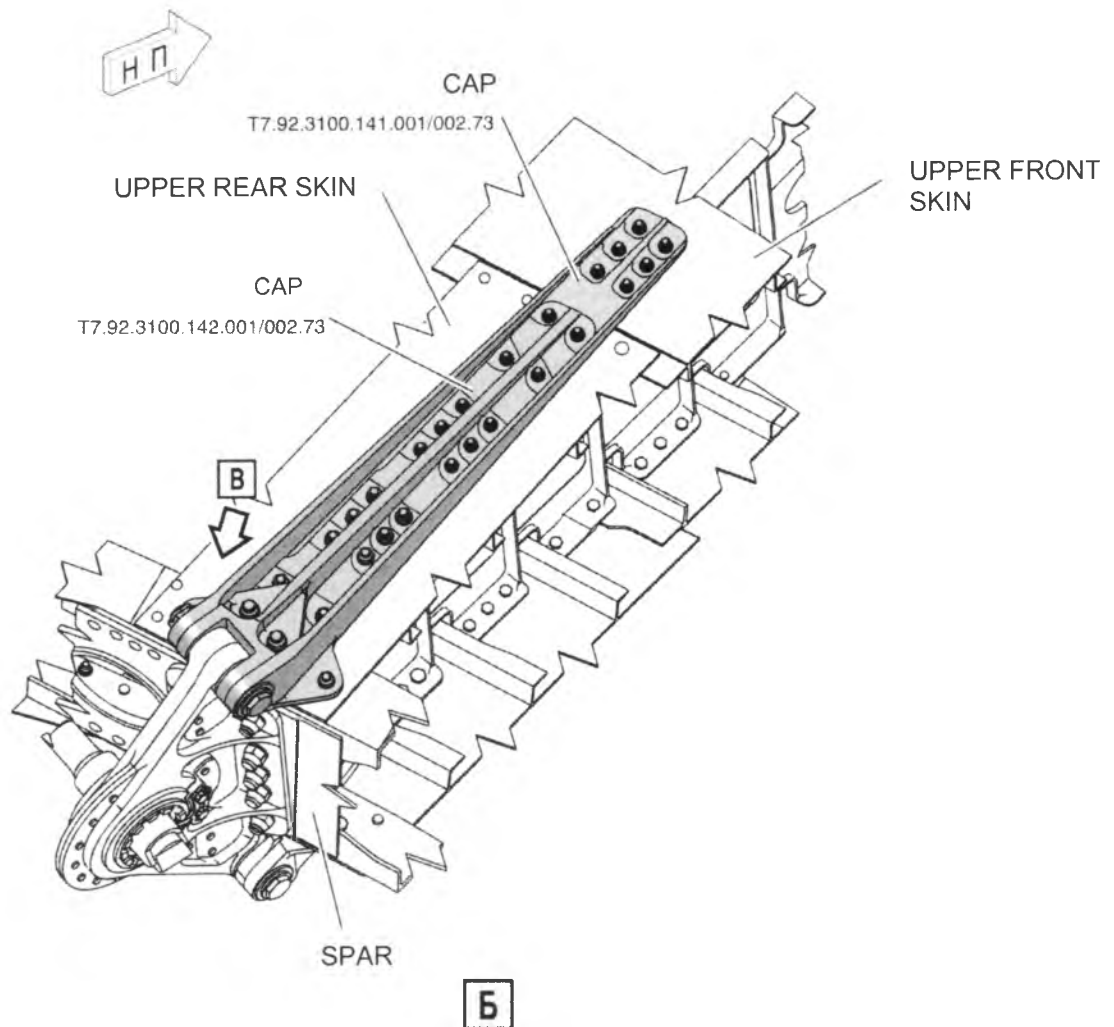

Demounting of the hollow bolts (T7.92.3100.077.000.73) along the upper hinge fitting of the stabilizer

Figure 1 (sheet 2 of 3)

Procedure for
replacement of T7.92.3100.077.000.73 hollow bolts to T7.92.3100.177.000.73 bolts

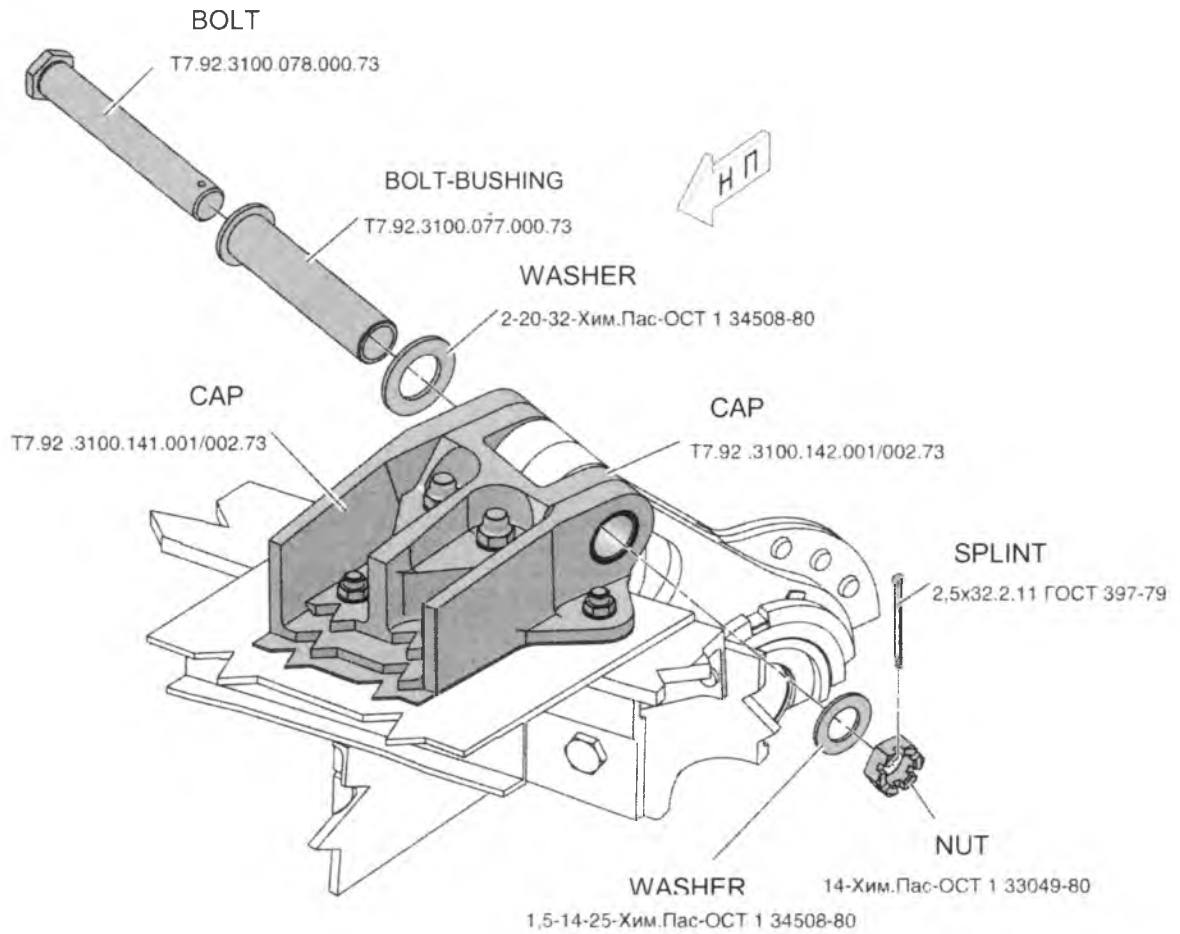

B

Demounting of the hollow bolts (T7.92.3100.077.000.73) along the upper hinge fitting of the stabilizer
Figure 1 (sheet 3 of 3)

**Procedure for
replacement of T7.92.3100.077.000.73 hollow bolts to T7.92.3100.177.000.73 bolts**

Mounting along the upper hinge fitting of the stabilizer

(2) Installation of the hollow bolt (T7.92.3100.177.000.73) along the upper hinge fitting of the stabilizer (see Fig. 2).

(a) Install the previously removed 2-20-32-Хим.Пас-ОСТ 1 34508-80 washer and new bolt-bushing (T7.92.3100.177.000.73) to the lug of the upper cap.

NOTE: Install the bushing using ЭРА paste.

(б) Install the previously removed bolt (T7.92.3100.078.000.73).

NOTE: Install the bushing using ЭРА paste.

(в) Install the previously removed 1,5-14-25-Хим.Пас-ОСТ 1 34508-80 washer.

(г) Install the previously removed 14-Хим.Пас-ОСТ 1 33049-80 nut.

(д) Install new 2.5x32.2.11 ГОСТ 397-79 splint.

(а) Clean the surfaces of the bolt, the protruding threaded portion, nut and washer from dirt with the cleaning rags dampened with НЕФРАС-С2-80/120 solvent.

(б) Apply to the bolt head (T7.92.3100.078.000.73), the protruding threaded portion, nut and washer: АК-070 priming, one layer; ЭП-140 enamel (grey), two layers.

Procedure for
replacement of T7.92.3100.077.000.73 hollow bolts to T7.92.3100.177.000.73 bolts

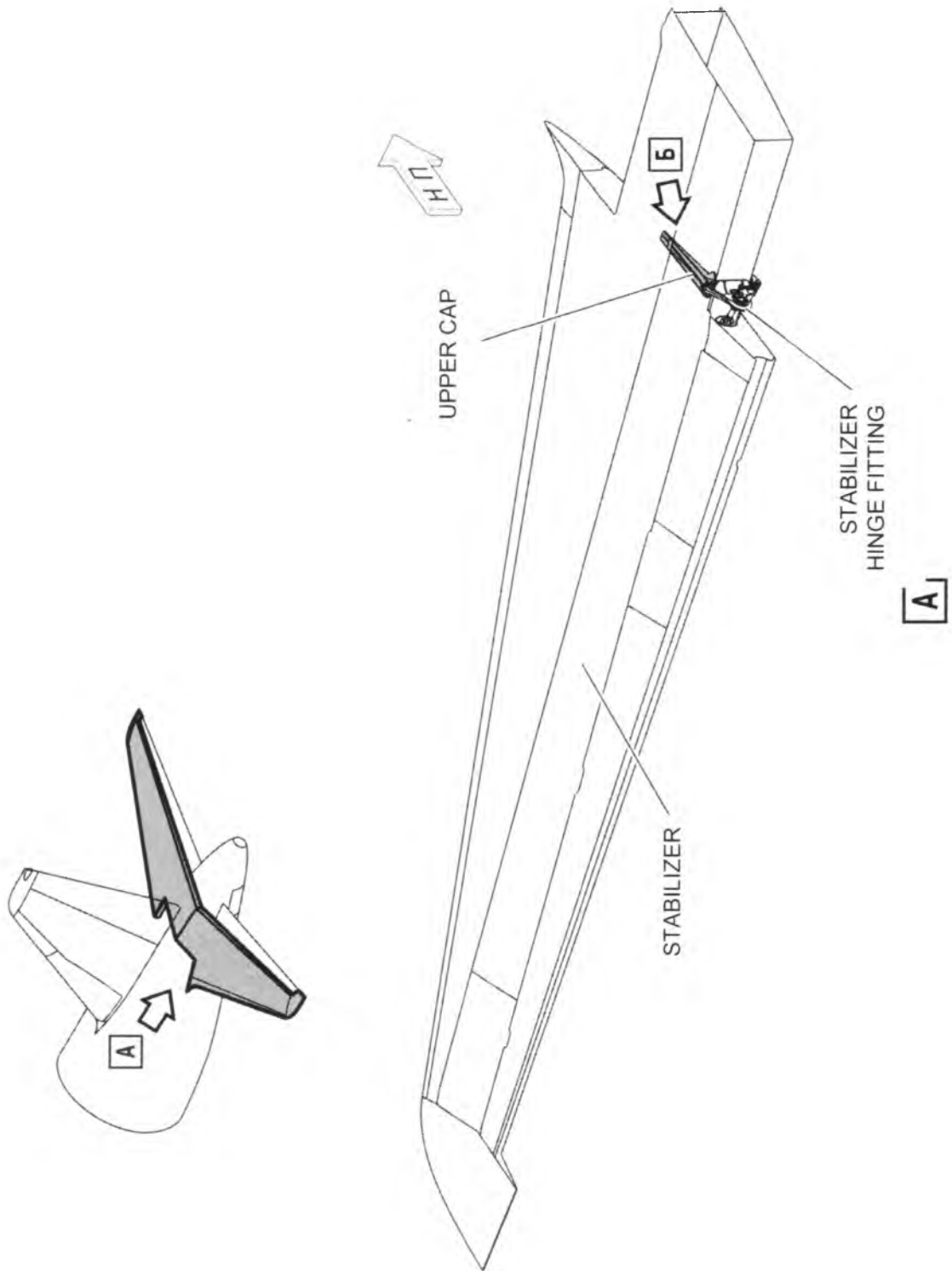

Installation of the hollow bolt (T7.92.3100.177.000.73) along the upper hinge fitting of the stabilizer
Figure 2 (sheet 1 of 3)

Procedure for
replacement of T7.92.3100.077.000.73 hollow bolts to T7.92.3100.177.000.73 bolts

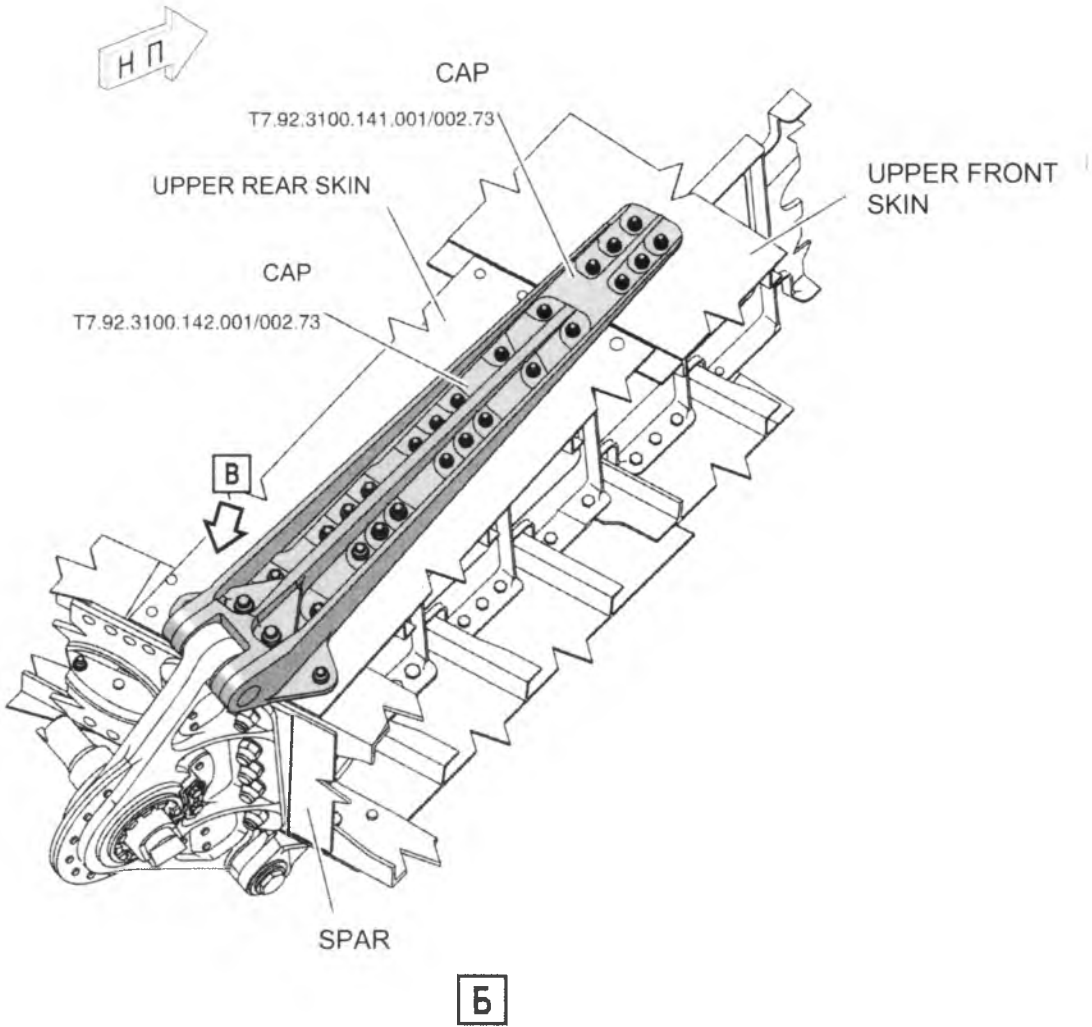

Installation of the hollow bolt (T7.92.3100.177.000.73) along the upper hinge fitting of the stabilizer
Figure 2 (sheet 2 of 3)

**Procedure for
replacement of T7.92.3100.077.000.73 hollow bolts to T7.92.3100.177.000.73 bolts**

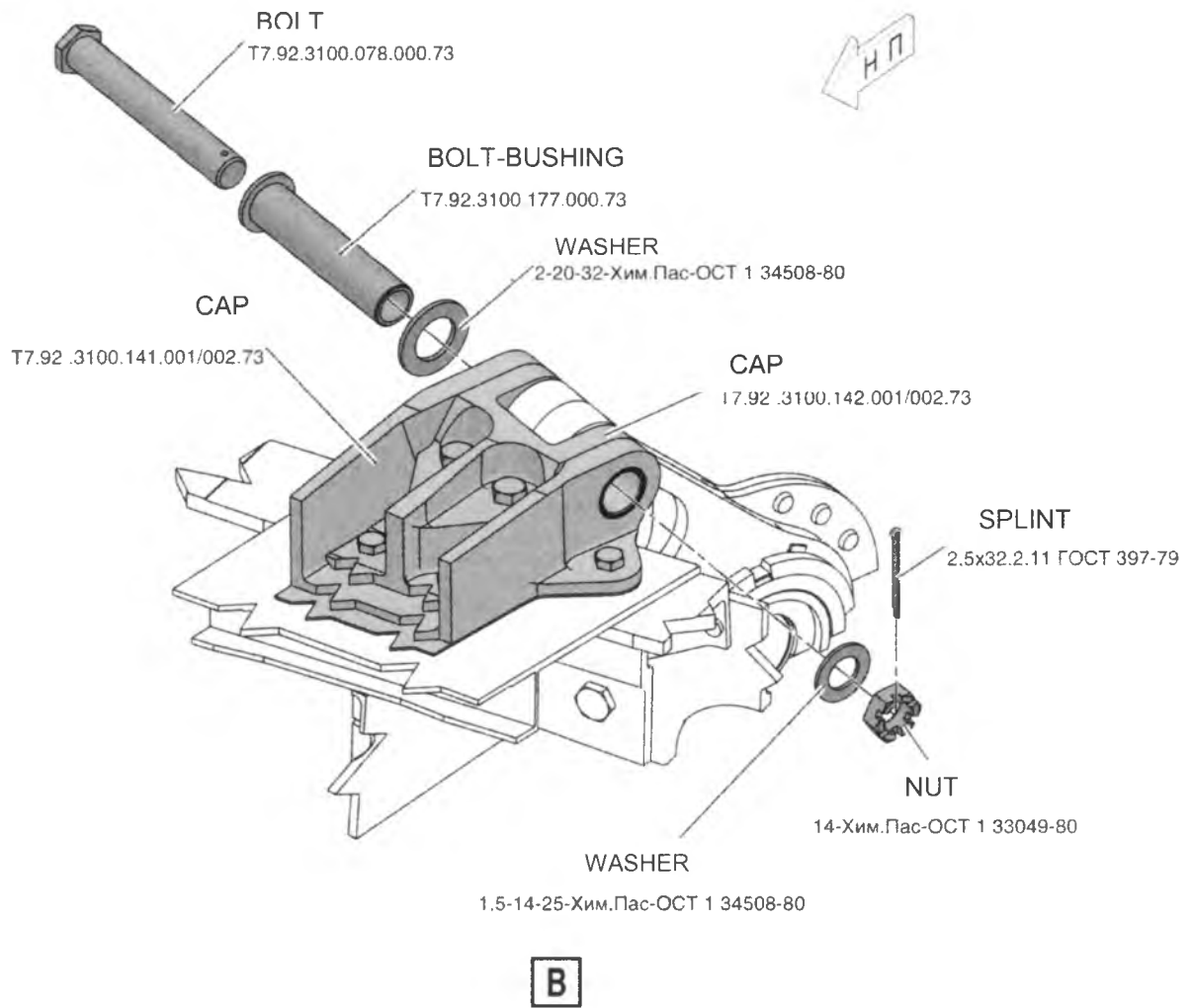

Installation of the hollow bolt (T7.92.3100.177.000.73) along the upper hinge fitting of the stabilizer
Figure 2 (sheet 3 of 3)

**Procedure for
replacement of T7.92.3100.077.000.73 hollow bolts to T7.92.3100.177.000.73 bolts**

Demounting along the lower hinge fitting of the stabilizer

- (3) Demounting the hollow bolt (T7.92.3100.077.000.73) along the lower hinge fitting of the stabilizer (see Fig. 3).
- (a) Clean the surfaces of the upper cap from a dirt with the cleaning rags dampened with НЕФРАС-С2-80/120 solvent if necessary.
 - (б) Remove the 2,5x32.2.11 ГОСТ 397-79 splint and discard.
 - (в) Remove the 14-Хим.Пас-ОСТ 1 33049-80 nut of the lower cap attachment to the fitting of the stabilizer. Save it the nut for the further installation.
 - (г) Remove the 1,5-14-25-Хим.Пас-ОСТ 1 34508-80 washer and save it for the further installation.
 - (д) Remove the bolt (T7.92.3100.078.000.73) and save it for the further installation.
 - (е) Carefully remove the bolt-bushing (T7.92.3100.077.000.73) from the lugs of the lower cap. Discard the bolt-bushing.
 - (ж) Remove the 2-20-32-Хим.Пас-ОСТ 1 34508-80 washer and save it for the further installation.

Procedure for
replacement of T7.92.3100.077.000.73 hollow bolts to T7.92.3100.177.000.73 bolts

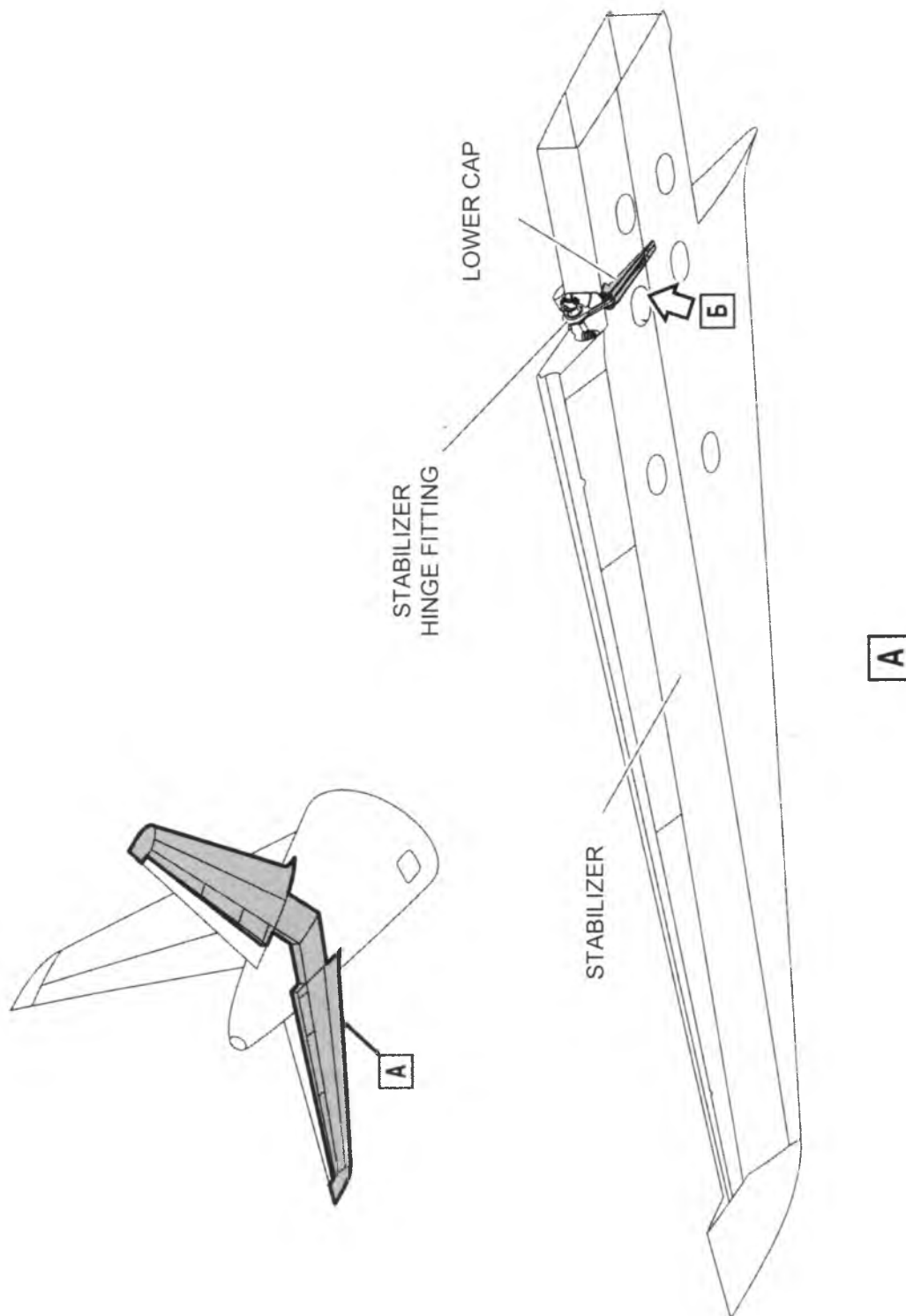

Demounting of the hollow bolt (T7.92.3100.077.000.73) along the lower hinge fitting of the stabilizer
Figure 3 (sheet 1 of 3)

Procedure for
replacement of T7.92.3100.077.000.73 hollow bolts to T7.92.3100.177.000.73 bolts

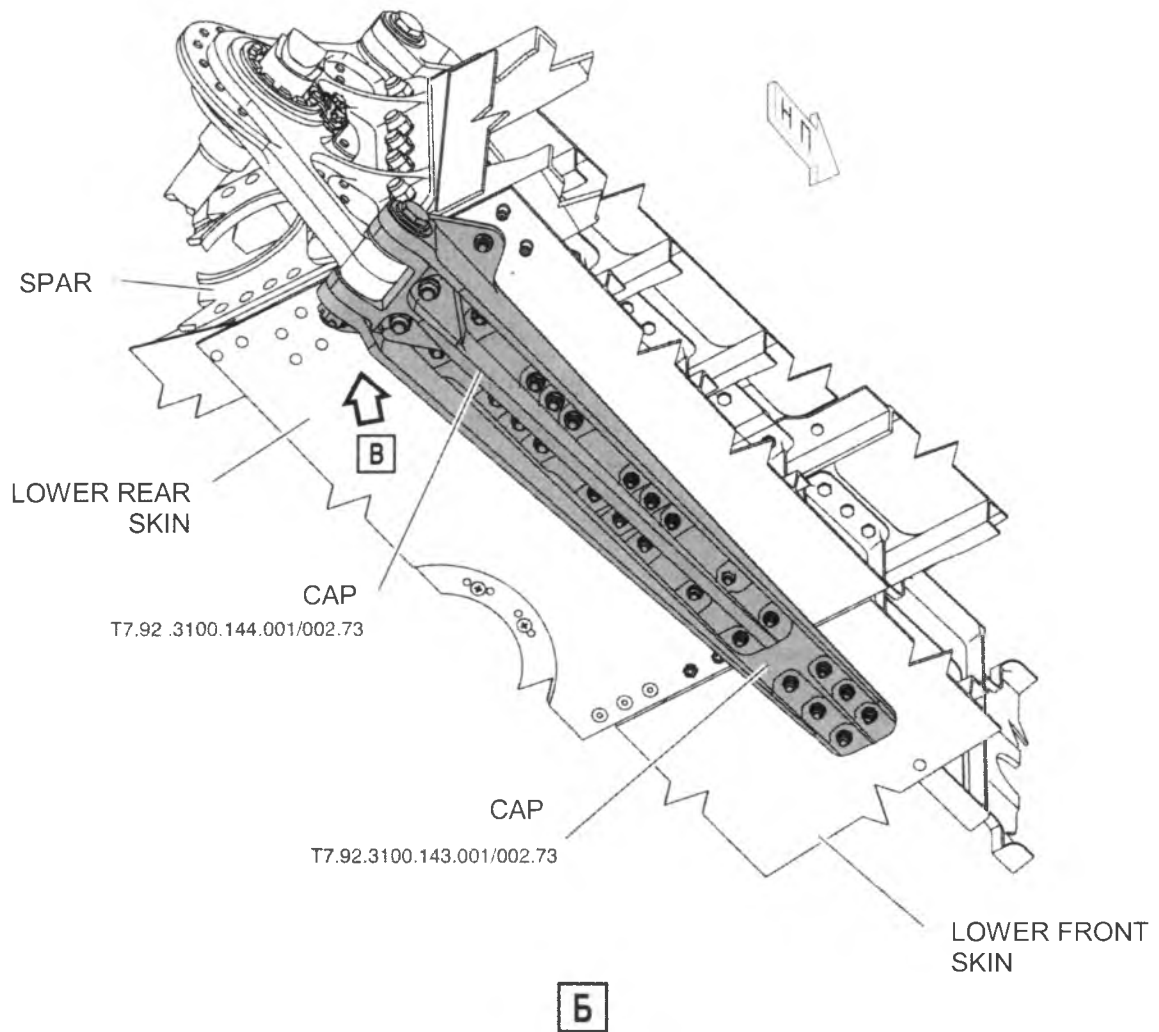

Demounting of the hollow bolt (T7.92.3100.077.000.73) along the lower hinge fitting of the stabilizer

Figure 3 (sheet 2 of 3)

Procedure for
replacement of T7.92.3100.077.000.73 hollow bolts to T7.92.3100.177.000.73 bolts

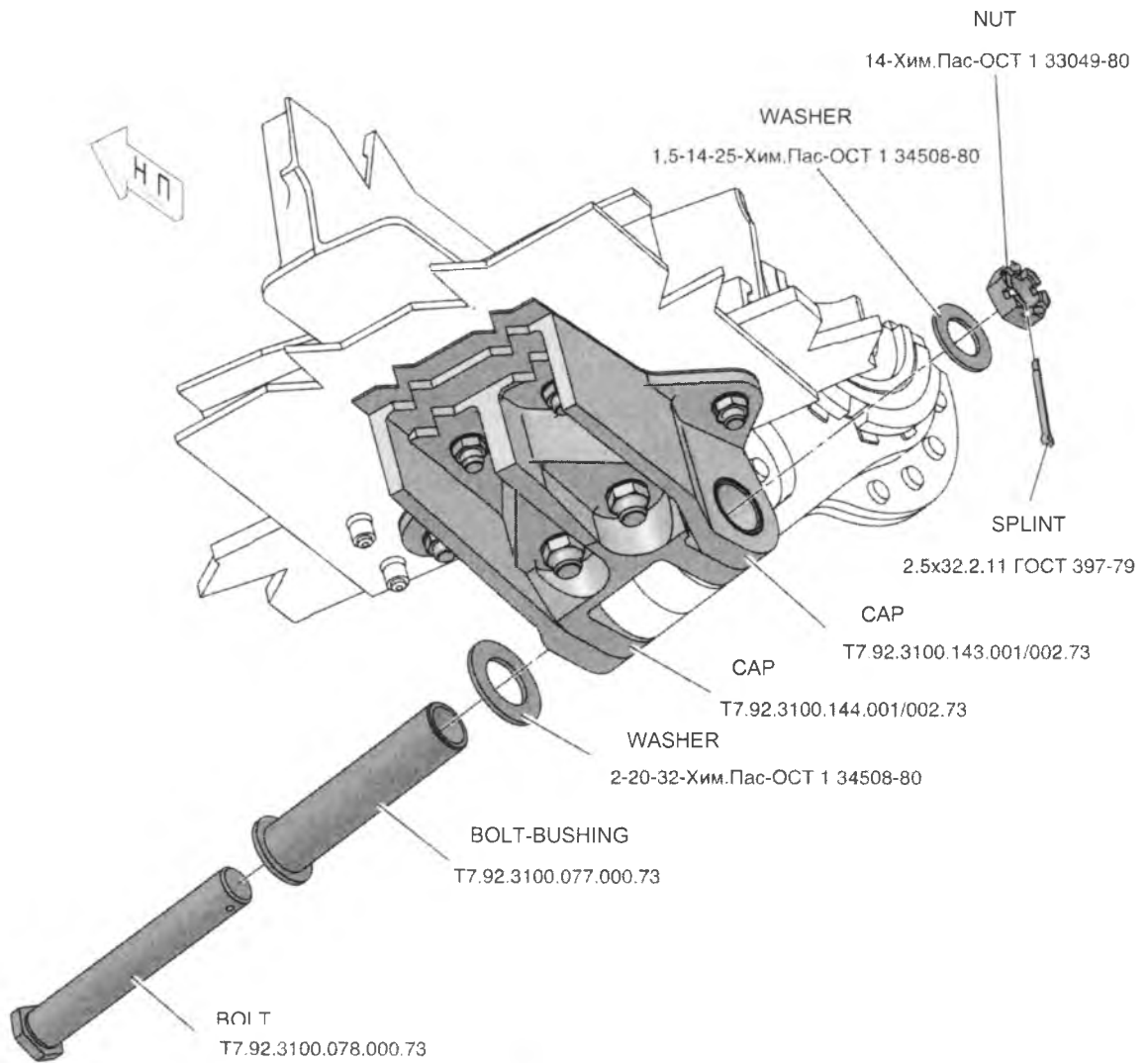

B

Demounting of the hollow bolt (T7.92.3100.077.000.73) along the lower hinge fitting of the stabilizer
Figure 3 (sheet 3 of 3)

**Procedure for
replacement of T7.92.3100.077.000.73 hollow bolts to T7.92.3100.177.000.73 bolts**

Mounting along the lower hinge fitting of the stabilizer

(4) Installation of the hollow bolt (T7.92.3100.177.000.73) along the lower hinge fitting of the stabilizer (See. Fig. 4).

- (a) Install the previously removed 2-20-32-Хим.Пас-ОСТ 1 34508-80 washer and new bushing (T7.92.3100.177.000.73) to the lug of the lower.

NOTE: Install the bushing using ЭРА paste.

- (б) Install the previously removed bolt (T7.92.3100.078.000.73).

NOTE: Install the bolt using ЭРА paste.

- (в) Install the previously removed 1,5-14-25-Хим.Пас-ОСТ 1 34508-80 washer.

- (г) Install the previously removed 14-Хим.Пас-ОСТ 1 33049-80 nut.

- (д) Install new 2,5x32.2.11 ГОСТ 397-79 splint.

- (е) Clean the surfaces of the bolt, the protruding threaded portion, nut and washer from dirt with cleaning rags dampened with НЕФРАС-С2-80/120 solvent.

- (ж) Apply to the bolt head (T7.92.3100.078.000.73) the protruding threaded portion, nut and washer: АК-070 priming, one layer; ЭП-140 enamel (grey), two layers.

Procedure for
replacement of T7.92.3100.077.000.7399 bolts
T7.92.3100.177.000.73 bolts

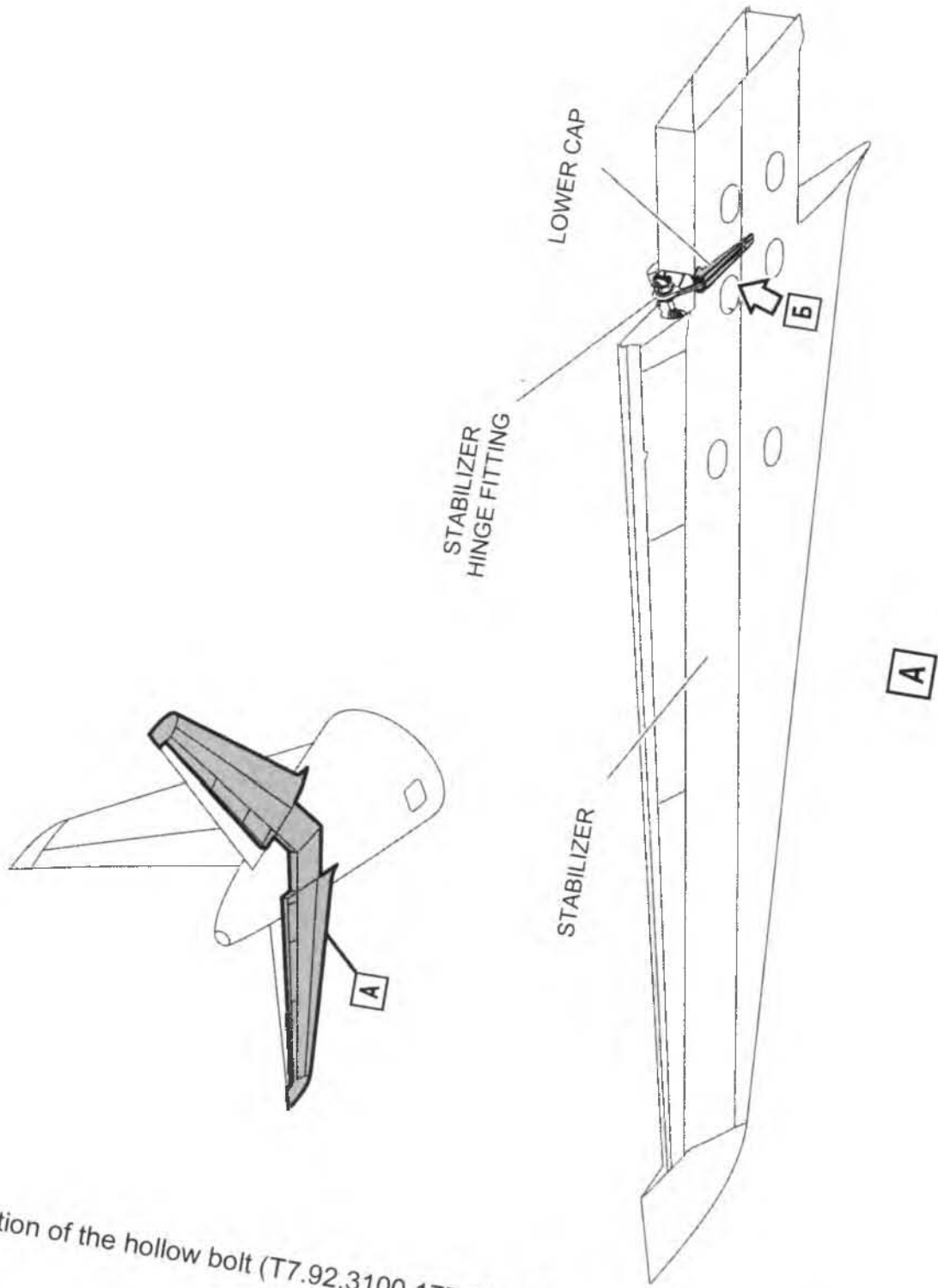

Installation of the hollow bolt (T7.92.3100.177.000.73) along the lower hinge fitting of the stabilizer
Figure 4 (sheet 1 of 3)

Procedure for
replacement of T7.92.3100.077.000.73 hollow bolts to T7.92.3100.177.000.73 bolts

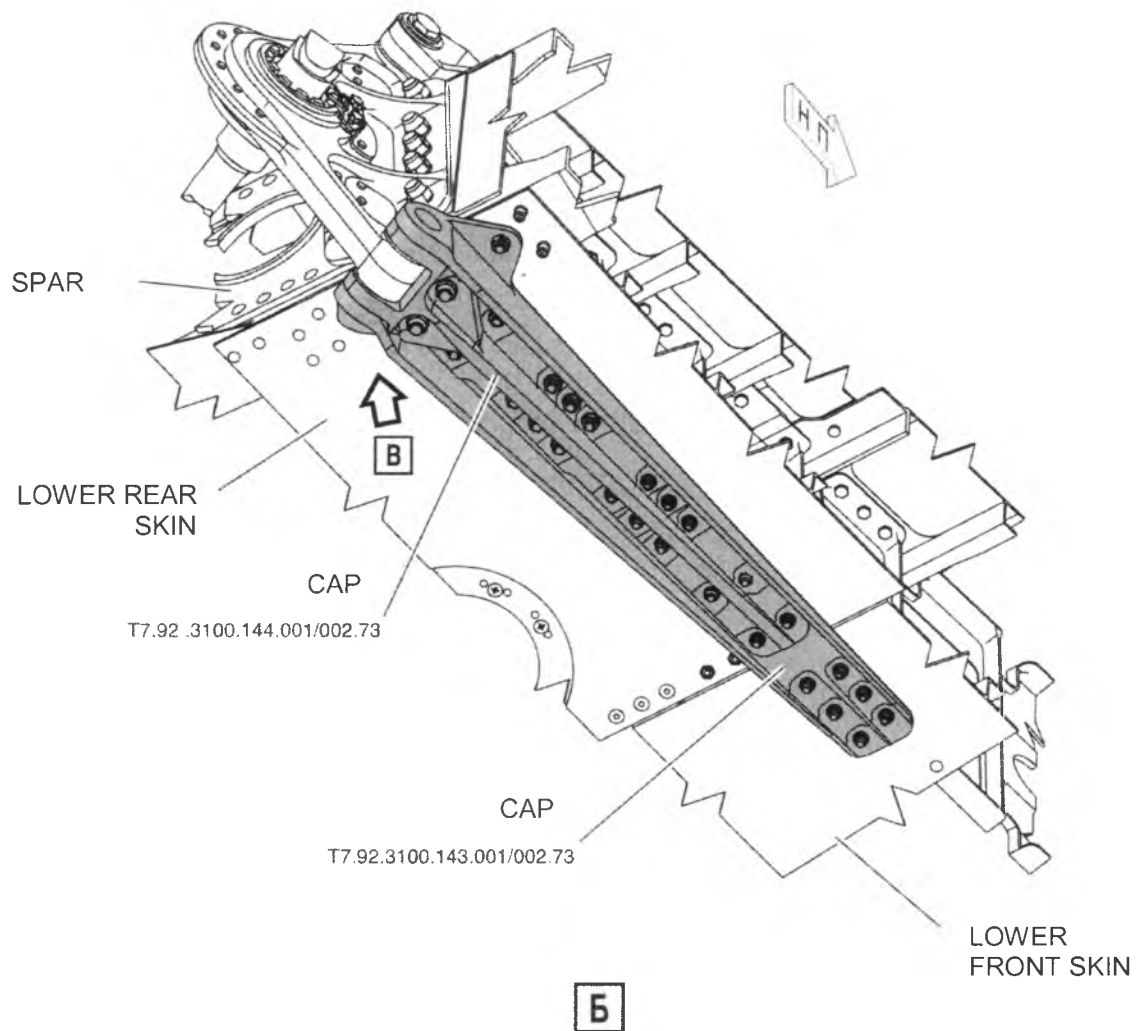

Installation of the hollow bolt (T7.92.3100.077.000.73) along the lower hinge fitting of the stabilizer

Figure 4 (sheet 2 of 3)

Procedure for
replacement of T7.92.3100.077.000.73 hollow bolts to T7.92.3100.177.000.73 bolts

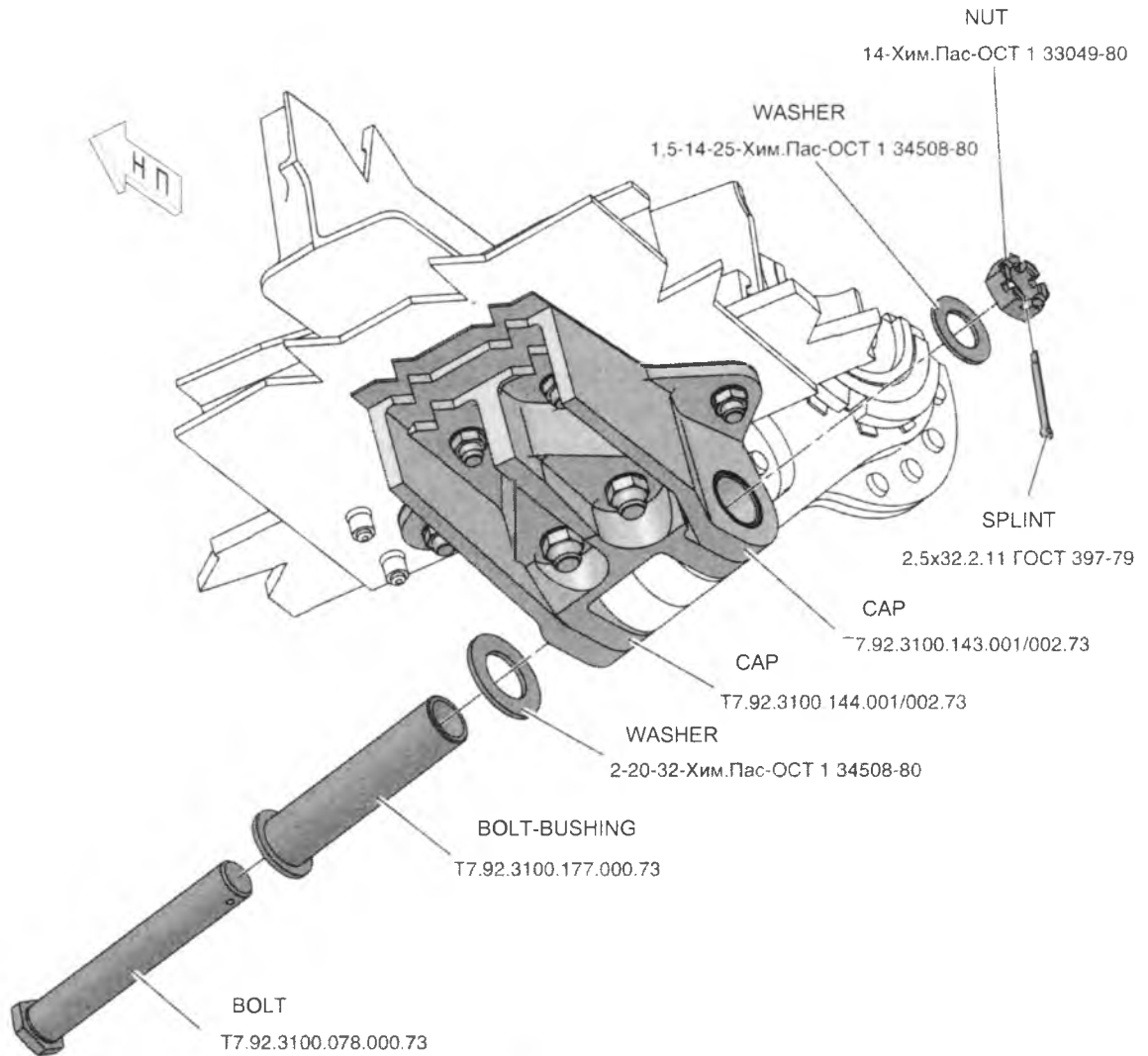

B

Installation of the hollow bolt (T7.92.3100.077.000.73) along the lower hinge fitting of the stabilizer
Figure 4 (sheet 3 of 3)